HP OpenVMS Command Definition, Librarian, and Message Utilities Manual

Order Number: AA-QSBDE-TE

January 2005

This manual describes how to use the Command Definition Utility to modify OpenVMS DCL, how to use the Librarian utility to create and maintain OpenVMS libraries, and how to use the Message utility to supplement OpenVMS system messages with messages of your own.

Revision/Update Information: This manual supersedes the *HP OpenVMS Command Definition, Librarian, and Message Utilities Manual, Version 7.3*

Software Version: OpenVMS I64 Version 8.2
OpenVMS Alpha Version 8.2

Hewlett-Packard Company
Palo Alto, California

© Copyright 2005 Hewlett-Packard Development Company, L.P.

Confidential computer software. Valid license from HP required for possession, use or copying. Consistent with FAR 12.211 and 12.212, Commercial Computer Software, Computer Software Documentation, and Technical Data for Commercial Items are licensed to the U.S. Government under vendor's standard commercial license.

The information contained herein is subject to change without notice. The only warranties for HP products and services are set forth in the express warranty statements accompanying such products and services. Nothing herein should be construed as constituting an additional warranty. HP shall not be liable for technical or editorial errors or omissions contained herein.

Intel and Itanium are trademarks or registered trademarks of Intel Corporation or its subsidiaries in the United States and other countries.

Printed in the US

ZK6100

The HP OpenVMS documentation set is available on CD-ROM.

This document was prepared using DECdocument, Version 3.3-1b.

Contents

| | |
|---|--------|
| Preface | vii |
| 1 Command Definition Utility | |
| CDU Description | CDU-3 |
| 1.1 Command Processing | CDU-3 |
| 1.1.1 Command String Components | CDU-3 |
| 1.1.2 System and Process Command Tables | CDU-4 |
| 1.2 Using CDU | CDU-4 |
| 1.3 Choosing a Table | CDU-4 |
| 1.3.1 Modifying Your Process Command Table | CDU-5 |
| 1.3.2 Adding a System Command | CDU-5 |
| 1.3.3 Creating an Object Module | CDU-6 |
| 1.4 Writing a Command Definition File | CDU-6 |
| 1.4.1 Defining Syntax | CDU-7 |
| 1.4.2 Defining Values | CDU-8 |
| 1.4.2.1 Built-In Value Types | CDU-8 |
| 1.4.2.2 User-Defined Keywords | CDU-9 |
| 1.4.3 Defining Command Verbs | CDU-10 |
| 1.4.4 Disallowing Entity Combinations | CDU-10 |
| 1.4.4.1 Specifying Expression Entities | CDU-11 |
| 1.4.4.2 Operators | CDU-14 |
| 1.4.5 Identifying Object Modules | CDU-15 |
| 1.5 Processing Command Definition Files | CDU-16 |
| 1.5.1 Adding Command Definitions to a Command Table | CDU-16 |
| 1.5.2 Deleting Command Definitions | CDU-17 |
| 1.5.3 Creating Object Modules | CDU-17 |
| 1.5.4 Creating New Command Tables | CDU-17 |
| 1.6 Using Command Language Routines | CDU-18 |
| CDU Usage Summary | CDU-19 |
| CDU File Statements | CDU-20 |
| DEFINE SYNTAX | CDU-21 |
| DEFINE TYPE | CDU-29 |
| DEFINE VERB | CDU-32 |
| IDENT | CDU-37 |
| MODULE | CDU-38 |

| | |
|-----------------------------|--------|
| CDU Qualifiers | CDU-39 |
| /ALPHA | CDU-40 |
| /DELETE | CDU-41 |
| /LISTING | CDU-42 |
| /OBJECT | CDU-43 |
| /OUTPUT | CDU-44 |
| /REPLACE | CDU-45 |
| /TABLE | CDU-46 |
| /VAX | CDU-47 |
| CDU Examples | CDU-48 |

2 Librarian Utility

| | |
|--|--------|
| LIBRARIAN Description | LIB-3 |
| 2.1 Types of Libraries | LIB-3 |
| 2.2 Structure of Libraries | LIB-4 |
| 2.3 Character Case of Library Keys | LIB-5 |
| 2.4 Shareable Image Libraries | LIB-5 |
| 2.5 Help Libraries | LIB-6 |
| 2.5.1 Creating Help Files | LIB-6 |
| 2.5.2 Formatting Help Files | LIB-7 |
| 2.5.3 Help Text Example | LIB-9 |
| 2.5.4 Retrieving Help Text | LIB-10 |
| 2.6 Using the Librarian Utility to Save Disk Space | LIB-12 |
| 2.7 Librarian Utility (LBR) Routines | LIB-12 |
| LIBRARIAN Usage Summary | LIB-13 |
| LIBRARIAN Qualifiers | LIB-15 |
| /ALPHA (VAX and Alpha only) | LIB-16 |
| /BEFORE | LIB-17 |
| /COMPRESS | LIB-18 |
| /CREATE | LIB-20 |
| /CROSS_REFERENCE | LIB-23 |
| /DATA | LIB-24 |
| /DELETE | LIB-25 |
| /EXTRACT | LIB-26 |
| /FULL | LIB-27 |
| /GLOBALS | LIB-28 |
| /HELP | LIB-29 |
| /HISTORY | LIB-30 |
| /INSERT | LIB-31 |
| /LIST | LIB-32 |
| /LOG | LIB-33 |
| /MACRO | LIB-34 |
| /MODULE | LIB-35 |
| /NAMES | LIB-36 |
| /OBJECT | LIB-38 |
| /ONLY | LIB-39 |

| | |
|---------------------------------|--------|
| /OUTPUT | LIB-40 |
| /REMOVE | LIB-41 |
| /SELECTIVE_SEARCH | LIB-42 |
| /SHARE | LIB-43 |
| /SINCE | LIB-44 |
| /SQUEEZE | LIB-45 |
| /TEXT | LIB-46 |
| /VAX (VAX and Alpha only) | LIB-47 |
| /WIDTH | LIB-48 |

3 Message Utility

| | |
|---|--------|
| MESSAGE Description | MSG-3 |
| 3.1 Message Format | MSG-3 |
| 3.2 Constructing Messages | MSG-4 |
| 3.2.1 The Message Source File | MSG-4 |
| 3.2.2 Compiling the Message Source File | MSG-5 |
| 3.2.3 Linking the Message Object Module | MSG-6 |
| 3.3 Using Message Pointers | MSG-6 |
| 3.4 The SET MESSAGE Command | MSG-8 |
| 3.5 Message Source Files | MSG-8 |
| MESSAGE Usage Summary | MSG-10 |
| MESSAGE Qualifiers | MSG-11 |
| /ALPHA | MSG-12 |
| /FILE_NAME | MSG-13 |
| /LIST | MSG-14 |
| /OBJECT | MSG-15 |
| /SYMBOLS | MSG-16 |
| /TEXT | MSG-17 |
| /VAX | MSG-18 |
| MESSAGE Commands | MSG-19 |
| Base Message Number Directive | MSG-20 |
| End Directive | MSG-21 |
| Facility Directive | MSG-22 |
| Identification Directive | MSG-24 |
| Literal Directive | MSG-25 |
| Message Definition | MSG-26 |
| Page Directive | MSG-29 |
| Severity Directive | MSG-30 |
| Title Directive | MSG-31 |

| | |
|-------------------------------|--------|
| MESSAGE Examples | MSG-32 |
|-------------------------------|--------|

Index

Examples

| | | |
|-----|-------------------------------------|--------|
| 2-1 | Help Text for LIBRARY Command | LIB-9 |
| 2-2 | HELP LIBRARY Display | LIB-10 |

Figures

| | | |
|-----|----------------------------------|-------|
| 3-1 | Message Code | MSG-4 |
| 3-2 | Creating a Message Pointer | MSG-7 |

Tables

| | | |
|-----|---|--------|
| 1-1 | Summary of CDU Operators | CDU-15 |
| 1-2 | How the DEFINE SYNTAX Statement Modifies the Primary DEFINE Statement | CDU-21 |
| 2-1 | Libraries Created by OpenVMS Platform | LIB-4 |
| 2-2 | LIBRARY Command Qualifier Compatibilities | LIB-15 |

Intended Audience

This manual is intended for programmers and general users of the OpenVMS operating system.

Document Structure

This manual is divided into three parts.

Chapter 1 describes the Command Definition Utility (CDU) and consists of the following sections:

- Description—Provides a full description of CDU.
- Usage Summary—Outlines the following information:
 - Invoking the utility
 - Exiting from the utility
 - Directing output
 - Restrictions or privileges required
- File Statements—Describes the statements used in building command definition files, including statement formats, parameters, and examples.
- Qualifiers—Describes qualifiers, including format, parameters, and examples.
- Examples—Provides additional CDU examples.

Chapter 2 describes the Librarian utility (LIBRARIAN) and consists of the following sections:

- Description—Provides a full description of LIBRARIAN.
- Usage Summary—Outlines the following information:
 - Invoking the utility
 - Exiting from the utility
 - Directing output
- Qualifiers—Describes qualifiers, including format, parameters, and examples.

Chapter 3 describes the Message utility (MESSAGE) and consists of the following sections:

- Description—Provides a full description of MESSAGE.
- Usage Summary—Outlines the following information:
 - Invoking the utility
 - Exiting from the utility

- **Qualifiers**—Describes qualifiers, including format, parameters, and examples.
- **Commands**—Describes source file statements, including format, parameters, and examples.
- **Examples**—Provides additional examples for using message files and pointer files.

Related Documents

For related information about these utilities, refer to the following documents:

- *HP OpenVMS DCL Dictionary*
- *HP OpenVMS Linker Utility Manual*

For additional information about HP OpenVMS products and services, access the HP website at the following location:

<http://www.hp.com/go/openvms>

Reader's Comments

HP welcomes your comments on this manual. Please send comments to either of the following addresses:

| | |
|-------------|--|
| Internet | openvmsdoc@hp.com |
| Postal Mail | Hewlett-Packard Company OSSG Documentation Group, ZKO3-4/U08 110 Spit Brook Rd. Nashua, NH 03062-2698 |

How To Order Additional Documentation

For information about how to order additional documentation, visit the following World Wide Web address:

<http://www.hp.com/go/openvms/doc/order>

Conventions

The following conventions are used in this manual:

| | |
|--|---|
| Ctrl/ <i>x</i> | A sequence such as Ctrl/ <i>x</i> indicates that you must hold down the key labeled Ctrl while you press another key or a pointing device button. |
| PF1 <i>x</i> | A sequence such as PF1 <i>x</i> indicates that you must first press and release the key labeled PF1 and then press and release another key or a pointing device button. |
| Return | In examples, a key name enclosed in a box indicates that you press a key on the keyboard. (In text, a key name is not enclosed in a box.) |

| | |
|--------------------|--|
| ... | Horizontal ellipsis points in examples indicate one of the following possibilities: <ul style="list-style-type: none"> • Additional optional arguments in a statement have been omitted. • The preceding item or items can be repeated one or more times. • Additional parameters, values, or other information can be entered. |
| . | Vertical ellipsis points indicate the omission of items from a code example or command format; the items are omitted because they are not important to the topic being discussed. |
| () | In command format descriptions, parentheses indicate that, if you choose more than one option, you must enclose the choices in parentheses. |
| [] | In command format descriptions, brackets indicate optional elements. You can choose one, none, or all of the options. (Brackets are not optional, however, in the syntax of a directory name in an OpenVMS file specification or in the syntax of a substring specification in an assignment statement.) |
| [] | In command format descriptions, vertical bars separating items inside brackets indicate that you choose one, none, or more than one of the options. |
| { } | In command format descriptions, braces indicate a required choice of options; you must choose one of the options listed. |
| bold text | This text style represents the introduction of a new term or the name of an argument, an attribute, or a reason. |
| <i>italic text</i> | Italic text indicates important information, complete titles of manuals, or variables. Variables include information that varies in system output (Internal error <i>number</i>), in command lines (<i>/PRODUCER=name</i>), and in command parameters in text (where <i>device-name</i> contains up to five alphanumeric characters). |
| UPPERCASE TEXT | Uppercase text indicates a command, the name of a routine, the name of a file, or the abbreviation for a system privilege. |
| Monospace text | Monospace type indicates code examples and interactive screen displays. In the C programming language, monospace type in text identifies the following elements: keywords, the names of independently compiled external functions and files, syntax summaries, and references to variables or identifiers introduced in an example. |
| - | A hyphen at the end of a command format description, command line, or code line indicates that the command or statement continues on the following line. |
| numbers | All numbers in text are assumed to be decimal unless otherwise noted. Nondecimal radices—binary, octal, or hexadecimal—are explicitly indicated. |

Command Definition Utility

CDU Description

The Command Definition Utility (CDU) creates, deletes, or changes command definitions in a command table. Command tables are data structures created by CDU and used by the command language interpreter (CLI) to parse and evaluate DIGITAL Command Language (DCL) commands.

There are two types of command tables: system command tables used to parse system commands and process command tables used to parse process-specific commands. CDU creates command tables from command definition files, from existing command tables, or from a combination of these sources. The new table can be either executable code or an object module.

The following sections describe:

- How DCL processes commands
- How to write command definitions
- How to modify command tables
- How to process command definitions
- How to use command language routines in programs

1.1 Command Processing

To write command definitions and modify command tables, you must understand how the DCL command interpreter processes commands. The process begins when DCL prompts you for a command and you enter an appropriate command string. Then DCL processes the command string from left to right using definitions in your process command table. Your process command table contains a list of valid commands and their attributes.

To parse a command string, DCL calls the `CLI$DCL_PARSE` routine to check each entity in the command string. If each entity is valid, DCL sets up an internal representation of the command string. Then DCL uses the `CLI$DISPATCH` routine to invoke the image or routine that executes the command. If the command string is not valid, DCL issues an error message.

The image or routine that executes a command must call the `CLI$PRESENT` and `CLI$GET_VALUE` routines to get information about the entities that were present in the command string. The image or routine uses this information to determine how to execute the command.

1.1.1 Command String Components

A command string can contain a **verb** that specifies the command to be executed, a **parameter** that specifies the verb object, and a **qualifier** that describes or modifies the action taken by the verb.

The DCL command definitions describe the allowable parameter values for each command. The command definitions also indicate whether or not qualifiers can take values and the value types that can be specified. Examples of qualifier values include file specifications, integer values, keywords, and character strings. Some commands (`SET` and `SHOW`) accept keywords as parameters. A keyword is a predefined string that can be used as a value for a parameter, qualifier, or another keyword.

CDU Description

The following example illustrates the components of a DCL command string:

```
$ DIFFERENCES/MODE=ASCII MYFILE.DAT YOURFILE.DAT
```

DIFFERENCES is the verb and /MODE is a qualifier that has as its value the keyword ASCII. MYFILE.DAT and YOURFILE.DAT are file specifications that function as the command parameters.

The next example shows a command that uses a keyword as a parameter value:

```
$ SHOW DEFAULT
```

Here, SHOW is the verb and DEFAULT is a keyword used as a parameter.

1.1.2 System and Process Command Tables

When you log in, the system command table in SYS\$LIBRARY:DCLTABLES.EXE is copied to your process and DCL uses this process command table to parse command strings. Changing your process command table does not affect SYS\$LIBRARY:DCLTABLES.EXE. To change the DCL tables, you need the CMKRNL privilege.

The system command table is created from source files called command definition files. A command definition file contains statements that name and describe verbs. Compaq maintains the command definition files for DCL; they are not shipped with your system.

1.2 Using CDU

To use CDU:

- Determine which table you want to create or modify. In general, you modify your process command table or the DCL table in SYS\$LIBRARY, or you create an object module for a new table.
- Choose a name and syntax for the command you define. Use a text editor to create a command definition file that defines the command.
- Use the DCL command SET COMMAND to add your command definition to the appropriate command table. You can modify your process command table or a specified command table file. You can also create an object module from your command definition file.
- Write the code for the image or routine that is invoked by the command you are adding to the command table.

Note that the foreign command facility is an alternate way to define command verbs. The foreign command allows you to pass information about a command string to an image. However, if you use the foreign command facility, your program must parse the command string; DCL does not parse the command string for you. For information about how to define a foreign command, see the *OpenVMS User's Manual*.

1.3 Choosing a Table

The type of table you are modifying or creating affects the way that you write a command definition, process this definition, and write the code that executes your command.

The most common tables that you modify or create include your process command table, the DCL table in SYS\$LIBRARY, and new tables that allow your programs to process commands.

1.3.1 Modifying Your Process Command Table

To add a command to your process command table, define the new command in a command definition file, specifying the name of an image for the command to invoke. Then use SET COMMAND to add the new command to your process command table and to copy the new table back to your process. For example, the following command adds a command in NEWCOMMAND.CLD to your process command table:

```
$ SET COMMAND NEWCOMMAND.CLD
```

Now you can enter the new command after the DCL prompt. DCL will parse the command and then invoke the image that executes the command. Note that, when you write the source code for the new command, you must use the command language routines CLI\$PRESENT and CLI\$GET_VALUE to obtain information about the command string. Refer to the *OpenVMS Utility Routines Manual* for additional information.

The first example in the CDU Examples section shows how to add a new command to your process command table and how to write the program that executes the new command.

To make the command in NEWCOMMAND.CLD available to you each time you log in, include the SET COMMAND command in your LOGIN.COM file.

1.3.2 Adding a System Command

Following are the instructions to add a command to the DCL command table in SYS\$LIBRARY:

- Define the command in a command definition file, specifying the name of an image for the command to invoke.
- Use SET COMMAND to add the new definition to the DCL command table and copy the new table back to SYS\$LIBRARY:

```
$ SET COMMAND/TABLE=SYS$LIBRARY:DCLTABLES.EXE -
  _$ /OUTPUT=SYS$COMMON:[SYSLIB]DCLTABLES.EXE NEWCOMMAND.CLD
```

- To make the new command available to other users, use the INSTALL utility:

```
$ INSTALL REPLACE SYS$LIBRARY:DCLTABLES.EXE
```

- To make the new command available to existing interactive processes, you can log out and log in again, or execute the following command:

```
$ SET COMMAND/TABLE=SYS$LIBRARY:DCLTABLES.EXE
```

Note

To ensure that the modified tables are written to the cluster common root, the output file specification is: SYS\$COMMON:[SYSLIB]. This ensures that the new command is available to all systems sharing the same system disk. This also avoids potential problems with future changes to the command tables due to copies of DCLTABLES being present in the SYS\$SPECIFIC:[SYSLIB] and SYS\$COMMON:[SYSLIB] areas referenced by SYS\$LIBRARY.

To locate potentially errant copies of the command tables, use the following command:

```
$ DIR SYS$SPECIFIC:[SYSLIB]DCLTABLES.EXE
```

CDU Description

1.3.3 Creating an Object Module

To create an object module for a new command table, define the commands in a command definition file, specifying the name of a routine in a program that executes the command. Then use SET COMMAND with the /OBJECT qualifier to create an object module from the command definition file. For example:

```
$ SET COMMAND/OBJECT NEWCOMMAND
```

Now link this object module with the program that uses the table. Note that, when you link a command table with your program, the program must perform the functions of a command interpreter. That is, the program must obtain the command string and call the parsing routine CLI\$DCL_PARSE to verify and create an internal representation of it. The program must also call CLI\$DISPATCH to invoke the appropriate routine. Each command routine must use the DCL interface routines CLI\$PRESENT and CLI\$GET_VALUE to get information about the command string that invoked the routine.

The second example in the CDU Examples section shows how to write and process command definitions for an object module and how to write a program that parses commands and invokes routines.

1.4 Writing a Command Definition File

A command definition file contains information that defines a command and its parameters, qualifiers, and keywords. In addition, the command definition file provides information about the image or routine that is invoked after the command string is successfully parsed.

Use a text editor to create a command definition file that contains the statements you need to describe your new command; you can use clauses to specify additional information for statements. The default file type for a command definition file is .CLD.

Use exclamation points to delimit comments. An exclamation point causes all characters that follow it on a line to be treated as comments.

Any statement and its clauses can be coded using several lines. No continuation character is necessary. (However, you cannot split names across two lines.) If you place a statement on one line, you can separate clauses in the statement with either commas or spaces.

You cannot abbreviate statement or clause names in the command definition language. All names (for example, DEFINE SYNTAX, PARAMETER, and so forth) must be spelled out completely.

Most statements and clauses accept user-supplied information such as verb names, qualifier names, image names, and so on. You can specify this information as a symbol or as a string.

If the statement requires that a term be specified as a string, enclose the term in quotation marks. A string can contain any alphanumeric or special characters. To include quotation marks within a string, use two quotation marks (""). For example, PARAMETER P1, LABEL=PORT, PROMPT="Enter ""one"" value" produces the following:

Enter "one" value

Note

To maintain compatibility with earlier releases, CDU accepts character strings that are not enclosed in quotation marks. However, Compaq recommends that you surround character strings in quotation marks. If you do not enclose a string in quotation marks, all alphabetic characters are converted to uppercase characters (capital letters).

If a statement requires that a term be specified as a symbol, do not enclose the term in quotation marks. A symbol name must start with a letter or a dollar sign. It can contain from 1 to 31 letters, numbers, dollar signs, and underscore characters.

The Command Definition Language includes the following statements:

- DEFINE SYNTAX syntax-name [verb-clause[, . . .]]
- DEFINE TYPE type-name [type-clause[, . . .]]
- DEFINE VERB verb-name [verb-clause[, . . .]]
- IDENT ident-string
- MODULE module-name

The following sections provide an overview of each CDU statement. See the CDU File Statements section for more detailed descriptions of each type of statement.

1.4.1 Defining Syntax

The DEFINE SYNTAX statement allows a command verb to use alternative syntax depending on the parameters, qualifiers, and keywords that are present in the command string. It redefines the syntax for a command verb previously defined by a DEFINE VERB or DEFINE TYPE statement, or it can be used to redefine the syntax for a command verb *redefined* by a previous DEFINE SYNTAX statement.

To define a syntax change, you must provide two DEFINE statements: a primary DEFINE statement and a secondary DEFINE statement. The primary DEFINE statement defines the affected command verb and it must include a SYNTAX=syntax-name verb clause to point to the secondary DEFINE statement. The secondary DEFINE statement defines the alternate syntax.

For example, you can write a command definition that uses a different syntax for a command verb when a particular qualifier is explicitly present, that is, not by default. When you include the specified qualifier in the command string, the syntax defined in the secondary DEFINE statement applies to the command verb described by the primary DEFINE statement.

This is the format for the DEFINE SYNTAX statement:

```
DEFINE SYNTAX syntax-name [verb-clause,[...]]
```

The **syntax-name** verb clause is the name of the alternate syntax definition. The verb clause specifies additional information about the syntax. You can use the same verb clauses in a DEFINE SYNTAX statement as are allowed in a DEFINE VERB statement, with one exception: you cannot use the SYNONYM verb clause with DEFINE SYNTAX.

CDU Description

The following example shows how a syntax change is used to specify an alternate command syntax when the /LINE qualifier is specified:

```
DEFINE VERB ERASE
    IMAGE "DISK1:[MYDIR]ERASE"
    QUALIFIER SCREEN
    QUALIFIER LINE, SYNTAX=LINE ❶

DEFINE SYNTAX LINE ❷
    IMAGE "DISK1:[MYDIR]LINE"
    QUALIFIER NUMBER, VALUE(REQUIRED)
```

- ❶ The DEFINE VERB statement defines the verb ERASE. This verb accepts two qualifiers, /SCREEN and /LINE. The qualifier /LINE uses an alternate syntax, specified with the SYNTAX=LINE clause. If you enter the command ERASE/LINE, the definitions in the DEFINE SYNTAX LINE statement override the definitions in the DEFINE VERB ERASE statement. However, if you enter the command ERASE/SCREEN or if you do not specify any qualifiers, the definitions in the DEFINE VERB ERASE statement apply.
- ❷ The DEFINE SYNTAX statement defines an alternate syntax called LINE. If you enter the command ERASE with the /LINE qualifier, the image DISK1:[MYDIR]LINE.EXE is invoked. The new syntax allows the qualifier /NUMBER, which requires a value.

1.4.2 Defining Values

To define values for parameters, qualifiers, or keywords, use the VALUE clause. When you use the VALUE clause, you can further define the value type with the TYPE clause.

With the TYPE clause, you can specify that a value type must be a built-in type (for example, a file specification), or you can specify that a value must be a user-defined keyword. Section 1.4.2.1 lists the built-in value types; Section 1.4.2.2 describes how to specify a user-defined keyword.

When you use the VALUE clause and do not define a value type, DCL processes the value in the following way. If the value is not enclosed in quotation marks, then DCL converts letters to uppercase and compresses multiple spaces and tabs to a single space. If the value is enclosed in quotation marks, then DCL removes the quotation marks, preserves the case of letters, and does not compress tabs and spaces. To include quotation marks within a quoted string, use two contiguous quotation marks ("") in the place you want the quotation marks to appear.

1.4.2.1 Built-In Value Types

The Command Definition Language provides the following built-in value types:

| | |
|--------------|---|
| \$ACL | The value must be an access control list. |
| \$DATETIME | The value must be an absolute time or a combination time. DCL converts truncated time values, combination time values, and keywords for time values (such as TODAY) to absolute time format. DCL fills blank date fields from the current system date and fills omitted time fields with zeros. |
| \$DELTATIME | The value must be a delta time. DCL fills missing fields with zeros. |
| \$EXPRESSION | The value must be a DCL-style expression. DCL evaluates the expression and provides the results. |

| | |
|-------------------------|---|
| \$FILE | The value must be a valid file specification. |
| \$NUMBER | The value must be an integer represented by either decimal, octal, or hexadecimal numbers. |
| \$PARENTHESESIZED_VALUE | The value must be enclosed in parentheses. Note that DCL does not remove the parentheses. |
| \$QUOTED_STRING | The value must be a string enclosed in quotation marks. Note that DCL does not remove the quotation marks. |
| \$REST_OF_LINE | DCL treats the rest of the line literally as the specified value, ignoring spaces or punctuation marks. DCL does not remove quotation marks when processing the string. |

The following example shows a parameter that must be specified as a file specification:

```
DEFINE VERB PLAY
    IMAGE "DISK1:[MYDIR]PLAY"
    PARAMETER P1, VALUE(TYPE=$FILE)
```

1.4.2.2 User-Defined Keywords

The `DEFINE TYPE` statement defines keywords that are acceptable for use as values for various command entities, including parameters, qualifiers, or other keywords.

To indicate that a command entity requires a keyword, use a `VALUE` clause of the following form in a definition statement:

```
DEFINE SYNTAX VALUE(TYPE=type-name)
```

The **type-name** points to the `DEFINE TYPE` statement that specifies the allowable keywords for the entity.

This is the format for the `DEFINE TYPE` statement:

```
DEFINE TYPE type-name [type-clause[,...]]
```

The **type-name** is the name of the keyword list, and the **type-clause** lists the acceptable keywords. Each type clause begins with the keyword `KEYWORD`, followed by one or more keywords that can be used with the parameter, qualifier, or keyword that references the keyword list. The next example includes two type-clauses in the `DEFINE TYPE` statement:

```
KEYWORD FAST, DEFAULT
KEYWORD SLOW
```

The following example illustrates the use of a `DEFINE TYPE` statement in conjunction with a `DEFINE VERB` statement:

```
DEFINE VERB SKIM ❶
    IMAGE "USER:[TOOLS]SKIM"
    QUALIFIER SPEED, VALUE(TYPE=SPEED_KEYWORDS) ❷

DEFINE TYPE SPEED_KEYWORDS ❸
    KEYWORD FAST, DEFAULT
    KEYWORD SLOW
```

- ❶ The `DEFINE VERB` statement defines a verb, `SKIM`, which invokes the image `[TOOLS]SKIM.EXE` and accepts the qualifier `/SPEED`.
- ❷ The `VALUE` clause indicates that the `/SPEED` qualifier accepts a list of keywords as defined by the `DEFINE TYPE SPEED_KEYWORDS` statement.

CDU Description

- ③ The DEFINE TYPE statement lists the keywords that can be used with the /SPEED qualifier; you can specify SKIM/SPEED=FAST or SKIM/SPEED=SLOW. If you specify the /SPEED qualifier without a value, the default is FAST.

1.4.3 Defining Command Verbs

The DEFINE VERB statement defines a new command verb and specifies its characteristics. You can define any number of verbs in a single command definition file.

The format for the DEFINE VERB statement is as follows:

```
DEFINE VERB verb-name [verb-clause[,...]]
```

The verb name is the name of the command. A verb clause specifies additional information about the verb. Verb clauses can appear in any order in the command definition file. Verb clauses are optional.

You can specify the following verb clauses:

| | |
|--------------|---|
| DISALLOW | Controls the use of an entity or a combination of entities. |
| NODISALLOWS | Permits all entities and entity combinations. |
| IMAGE | Specifies an image to be invoked by the verb. |
| PARAMETER | Defines a command parameter. |
| NOPARAMETERS | Disallows parameters. |
| QUALIFIER | Defines a command qualifier. |
| NOQUALIFIERS | Disallows qualifiers. |
| ROUTINE | Specifies a routine to be invoked by the verb. |
| SYNONYM | Specifies a verb synonym. |

The following example illustrates a DEFINE VERB statement:

```
DEFINE VERB SEARCH ①  
    IMAGE "SEARCH" ②  
    PARAMETER P1, LABEL=SOURCE, PROMPT="File", VALUE(REQUIRED) ③
```

- ① The DEFINE VERB statement names the verb SEARCH.
- ② The IMAGE verb clause identifies the image to be invoked at run time.
- ③ The PARAMETER verb clause defines the first parameter to appear after the verb in the command string. LABEL, PROMPT, and VALUE are parameter clauses that further define the parameter. LABEL defines a name that the image uses to refer to the parameter. PROMPT indicates the prompt string to be issued if you do not specify the parameter in the command string. VALUE uses the REQUIRED clause to indicate that the parameter must be present in the command string.

1.4.4 Disallowing Entity Combinations

When you define a verb, you can use the DISALLOW verb clause to selectively disallow the use of one or more entities with the verb.

The DISALLOW verb clause has the following format:

```
DISALLOW expression
```

The **expression** in the clause specifies the disallowed entities and you can use any of the various logical operators (exclusive-OR, AND, OR, and so forth) to define them. When a command string is parsed, each entity in the expression is tested to determine if the entity is present (true) or absent (false). If an entity is present by default but is not explicitly present in the command string, the entity is evaluated as absent (false).

After each entity is evaluated, the logical operations are performed. If the result is true, the command string is disallowed. If the result is false, the command string is valid.

For example, a command definition might contain a DEFINE VERB statement that defines the verb SPORTS with three qualifiers: /TENNIS, /BOWLING, and /BASEBALL. However, you might want to make the qualifiers mutually exclusive. The following example shows how to use the DISALLOW verb clause to put this restriction into the command definition file:

```
DEFINE VERB SPORTS
    IMAGE      "DISK3:[WILSON]SPORTS"
    QUALIFIER  TENNIS
    QUALIFIER  BOWLING
    QUALIFIER  BASEBALL
    DISALLOW  ANY2(TENNIS, BOWLING, BASEBALL)
```

The DISALLOW verb clause indicates that a command string is invalid if it contains more than one of the qualifiers /TENNIS, /BOWLING, or /BASEBALL.

Note that, when you specify any entity in a DISALLOW expression, the search context is the entire command string. Therefore, local qualifiers are treated as if they were global. The following example shows the global context of the search:

```
DEFINE VERB TEST
    IMAGE      "DISK3:[WORK]TEST"
    PARAMETER  P1
    PARAMETER  P2
    QUALIFIER  QUAL1
    QUALIFIER  QUAL2,PLACEMENT=LOCAL
    QUALIFIER  QUAL3,PLACEMENT=LOCAL
    DISALLOW  P1 AND QUAL1
    DISALLOW  QUAL2 AND QUAL3
```

Thus, the following two commands would be disallowed:

```
TEST P1 P2/QUAL1
TEST P1/QUAL2 P2/QUAL3
```

The global search context applied to local qualifiers is used only with DISALLOW processing, not with normal command parsing.

1.4.4.1 Specifying Expression Entities

When you specify entities in an expression, you need to uniquely identify the entities that are disallowed. You can specify an entity using one of the following:

- A parameter, qualifier, or keyword name or label
- A keyword path
- A definition path

CDU Description

Names and Labels

You can refer to a parameter or qualifier using its name or label if the entity is defined in the current definition. To refer to a keyword, you can use its name or label if the keyword is in a keyword path that starts from the current definition, and if the keyword name or label is unique. (See the next subsection for more information about keyword paths.)

If the LABEL=label-name keyword is used to assign a label to an entity, use the label name to refer to the entity. Otherwise, use the entity name.

The following example disallows combinations of entities:

```
DEFINE VERB COLOR
    IMAGE "WORK:[JUDY]COLOR"
    QUALIFIER RED
    QUALIFIER BLUE
    QUALIFIER GREEN, VALUE(TYPE=GREEN_AMOUNT)
    DISALLOW RED AND ALL
    DISALLOW BLUE AND ALL

DEFINE TYPE GREEN_AMOUNT
    KEYWORD ALL
    KEYWORD HALF
```

In this example, you can use the qualifier names RED and BLUE in the DISALLOW verb clause because both names are used in the current definition. You can use the keyword ALL because it is in a keyword path that starts within the current definition (the TYPE=GREEN_AMOUNT qualifier clause starts the path) and the keyword name is unique.

The DISALLOW clauses indicate that the following command strings are not valid:

```
$ COLOR/RED/GREEN=ALL
$ COLOR/BLUE/GREEN=ALL
```

To refer to a parameter or qualifier in another definition or to refer to a keyword whose path begins in another DEFINE statement, you must use a definition path.

Keyword Paths

A keyword path provides a way to uniquely identify a keyword. You can refer to a keyword using a keyword path if the keyword is in a path that starts from the current definition and if the keyword name or label is not unique. You can also use a keyword path if the same keyword can be used with more than one parameter or qualifier.

A keyword path contains a list of entity names or labels that are separated by periods. The first name in a keyword path is the name (or label) of the first entity that references the keyword's value type definition. A keyword path can contain up to eight names (the first parameter or qualifier definition, plus seven DEFINE TYPE keyword definitions).

If a keyword is assigned a label name, use the label name in the keyword path. Otherwise, use the keyword name. You can omit names that are not needed to resolve a keyword reference from the beginning of a keyword path. However, you must include enough names to uniquely reference the keyword.

The following command string illustrates a situation that requires keyword paths to uniquely identify keywords. In this command string, you can use the same keywords with more than one qualifier. (In the command definition file, two qualifiers refer to the same DEFINE TYPE statement.)

```
$ NEWCOMMAND/QUAL1=(START=5,END=10)/QUAL2=(START=2,END=5)
```

The keyword path QUAL1.START identifies the keyword START when it is used with QUAL1; the keyword path QUAL2.START identifies the keyword START when it is used with QUAL2. The name START is an ambiguous reference if used alone.

To disallow use of the keyword QUAL1.START when a third qualifier (QUAL3) is present, use the following line in the command definition file:

```
DISALLOW QUAL1.START AND QUAL3
```

Although you cannot use QUAL1.START when QUAL3 is present, you can still use QUAL2.START with QUAL3.

The following example contains a keyword (ALL) that appears in two DEFINE TYPE statements:

```
DEFINE VERB COLOR
    IMAGE "WORK:[JUDY]COLOR"
    QUALIFIER RED, VALUE(TYPE=RED_AMOUNT)
    QUALIFIER GREEN, VALUE(TYPE=GREEN_AMOUNT)
    DISALLOW RED AND GREEN.ALL
    DISALLOW GREEN AND RED.ALL

DEFINE TYPE RED_AMOUNT
    KEYWORD ALL
    KEYWORD MIXED

DEFINE TYPE GREEN_AMOUNT
    KEYWORD ALL
    KEYWORD HALF
```

In this example, you must use the keyword path RED.ALL to refer to the ALL keyword when it is used in the value type definition RED_AMOUNT; you must use the keyword path GREEN.ALL to refer to the ALL keyword when it is used in the value type definition GREEN_AMOUNT.

Definition Paths

A definition path links a syntax definition to an entity that is defined in another DEFINE statement. For example, a definition path is needed when a syntax definition provides new disallow clauses for parameters or qualifiers that are defined in a primary definition.

A definition path has the following format:

```
<definition-name>entity-spec
```

The definition name is the name of the DEFINE statement where the entity is defined or the keyword path begins. The entity specification can be an entity name, a label, or a keyword path. The angle brackets are required.

For example:

```
DISALLOW <SKIP>FIRST
```

This clause disallows a command string if the entity FIRST (specified in the DEFINE VERB statement for the command verb SKIP) is present.

CDU Description

The next example uses a keyword path and a definition path:

```
DISALLOW <FILE>BILLS.ELECT AND GAS
```

This clause disallows a command string if the entity described by the keyword path `BILLS.ELECT` (which originates in the `DEFINE VERB` statement for the command verb `FILE`) is present.

CDU does not check a definition path to determine whether the path refers to an entity that is valid in a given context. If you use a definition path to specify an entity that is not valid in a particular context, results are unpredictable. For example, if you try to disallow the qualifier `NOTES` in the `DEFINE SYNTAX` statement, the entity `NOTES` would not be recognized as valid because the path to `BILL_TYPES` is not established in the `DEFINE VERB` statement for the command verb `READ`.

```
DEFINE VERB FILE
    QUALIFIER BILLS, SYNTAX=BILL_TYPES
    QUALIFIER RECEIPTS

DEFINE VERB READ
    QUALIFIER NOTES

DEFINE SYNTAX BILL_TYPES
    DISALLOW <READ>NOTES
```

Although the `DISALLOW` clause correctly identifies an entity in the command definition file, this entity is not valid in the `DEFINE SYNTAX` statement. However, the clause `DISALLOW <FILE>RECEIPTS` is valid in the `DEFINE SYNTAX` statement. The `DEFINE SYNTAX` statement inherits the qualifier `RECEIPTS` from the primary `DEFINE` statement (`FILE`) because no qualifiers are specified.

See the description of the `DEFINE SYNTAX` statement in the `CDU File Statements` section for more information about how entities are inherited by `DEFINE SYNTAX` statements.

1.4.4.2 Operators

A command definition can include one or more expressions of the relationship between an action verb and one or more objects of the verb (entities) that can be qualifiers, parameters, or keywords in various combinations. For example, the following expression states that the command is disallowed if it contains *both* of the previously defined qualifiers `SINCE` and `BEFORE`:

```
DISALLOW SINCE AND BEFORE
```

The logical operator `AND` stipulates that the command is invalid only when both qualifiers are present. When an expression contains logical operators, the operators are evaluated after the related command entities are determined to be present (logical true) or absent (logical false). If the *result* of the expression is true (that is, if both qualifiers are present), the command is disallowed. Conversely, if the result is false (one or none of the qualifiers is present), the command is accepted.

Table 1–1 shows the operators you can use in command definition expressions and the order in which CDU evaluates these operators. The highest precedence value is 1. When an expression contains two or more operators of equal precedence, CDU evaluates the leftmost operator first.

Table 1–1 Summary of CDU Operators

| Operator | Precedence | Meaning |
|----------|------------|---|
| ANY2 | 1 | True if any two or more of the entities listed are present |
| NEG | 1 | True if the negated form of the entity is present |
| NOT | 1 | True if the entity is not present or if an entity is present by default |
| AND | 2 | True if both entities are present |
| OR | 3 | True if either entity is present |

The following example shows how to use the AND operator:

```
DISALLOW TERMINAL AND PRINTER
```

This statement disallows the command string if both entities (TERMINAL and PRINTER) are present.

You can use parentheses to override the order in which operations are evaluated; operations within parentheses are evaluated first. For example:

```
DISALLOW FAST AND (SLOW OR STILL)
```

The parentheses force the OR operator to be evaluated before the AND operator. Therefore, if the result of SLOW OR STILL is true, and if FAST is present in the command string, then the string is disallowed.

1.4.5 Identifying Object Modules

Use the MODULE and IDENT statements to provide identifying information if your command definition file is to create an object module. (You can create an object module from a command definition file with the command SET COMMAND/OBJECT. The object module contains a command table that you can link with your program.)

The MODULE statement assigns a symbolic name to the object module containing the command table. This is the format for the MODULE statement:

```
MODULE module-name
```

The **module-name** is the symbolic name for the object module.

The IDENT statement provides additional information in a quoted string format to identify the module. Typically, this might be the date the module was created or the name of the creator. This is the format for the IDENT statement:

```
IDENT ident-string
```

The **ident-string** is a quoted string having up to 31 characters.

The following sample command definition file illustrates the use of the MODULE and IDENT statements:

```
MODULE TABLE ❶
IDENT "Updated 4/15/92" ❷
DEFINE VERB SAVE ❸
    ROUTINE SAVE _ROUT
```

CDU Description

```
DEFINE VERB GET      ③  
    ROUTINE GET_ROUT
```

- ① The `MODULE` statement assigns the name `TABLE` to the command table that CDU creates when you use the command `SET COMMAND/OBJECT` to develop an object module for the new command.
- ② The `IDENT` statement provides additional identifying information. In this example, it shows the date when the command definition file was updated.
- ③ The `DEFINE VERB` statements define command verbs that can be used by the main program to invoke appropriate routines.

1.5 Processing Command Definition Files

A command definition file must be translated into an executable command table before the commands in the table can be parsed and executed. To perform this translation, use the DCL command `SET COMMAND` to invoke the Command Definition Utility.

The command `SET COMMAND` has the following modes:

| | |
|----------------------------------|--|
| <code>SET COMMAND/DELETE</code> | Deletes command definitions from a command table |
| <code>SET COMMAND/OBJECT</code> | Creates an object file from a command definition file |
| <code>SET COMMAND/REPLACE</code> | Adds or replaces definitions in a command table using definitions from a command definition file |

The `/DELETE`, `/OBJECT`, and `/REPLACE` qualifiers are mutually exclusive; you can use only one `SET COMMAND` mode in a command string. In addition to the qualifiers that specify modes, `SET COMMAND` provides the following qualifiers:

| | |
|---------------------------|---|
| <code>/[NO]LISTING</code> | Controls whether an output listing is created |
| <code>/[NO]OUTPUT</code> | Controls where the modified command table should be written |
| <code>/TABLE</code> | Specifies the command table that is to be modified |

See the `CDU Qualifiers` section for additional information.

1.5.1 Adding Command Definitions to a Command Table

Use the `/REPLACE` qualifier to add or replace verbs in the command table. By default, `SET COMMAND` uses the `/REPLACE` mode to add commands to your process command table and to return the modified command table to your process.

The following example shows how to add the new command `SKIP` to your process command table:

```
$ SET COMMAND SKIP
```

In this example, `SET COMMAND` adds the definitions from the command definition file `SKIP.CLD` to your process command table. The modified table replaces your original process command table. The `/REPLACE` qualifier is present by default, so you do not need to explicitly specify it in the command string.

To modify a command table other than your process table, use the `/TABLE` qualifier and the `/OUTPUT` qualifier.

1.5.2 Deleting Command Definitions

Use the /DELETE qualifier to delete a command name from a command table. By default, commands are deleted from your process command table. The following example shows how to delete the command SKIP from your process command table:

```
$ SET COMMAND/DELETE=SKIP
```

1.5.3 Creating Object Modules

Use the /OBJECT qualifier to create an object module from a command definition file. When you enter the following sample command, CDU creates an object module, NEWCOMS.OBJ, containing a command table with the verb definitions from NEWCOMS.CLD:

```
$ SET COMMAND/OBJECT NEWCOMS
```

You can then link NEWCOMS.OBJ with a program that parses commands using the new command table.

1.5.4 Creating New Command Tables

You cannot use the /OBJECT qualifier to create an object module from a command definition file that contains the IMAGE clause. However, you can create an empty command table to which you can add verbs that invoke images. The following is a step-by-step example of how to do this:

1. Create an empty command table by developing a command definition file that contains only a MODULE statement to define the module name and an IDENT statement. In the following example, CDU creates the empty command table, TEST_TABLE, from a command definition file named TEST_TABLE.CLD:

```
MODULE TEST_TABLE
IDENT "New Command table"
```

2. Create an object module (TEST_TABLE.OBJ) from TEST_TABLE.CLD:

```
$ SET COMMAND/OBJECT TEST_TABLE.CLD
```

3. Link TEST_TABLE.OBJ to create a shareable image, TEST_TABLE.EXE:

```
$ LINK/SHARE/NOTRACEBACK TEST_TABLE
```

4. Create a command definition file that defines verbs that invoke images. In the following example, the command definition file VERBS.CLD includes two statements that call existing images:

```
DEFINE VERB PASS
    IMAGE "DISK4:[ROSEN]PASS"
DEFINE VERB THROW
    IMAGE "DISK4:[ROSEN]THROW"
.
.
.
```

5. Add the new commands in VERBS.CLD to the empty command table in TEST_TABLE.EXE and write the modified table back to the file TEST_TABLE.EXE. The /TABLE and /OUTPUT qualifiers specify the input and output table files. For example:

CDU Description

```
$ SET COMMAND/TABLE=TEST_TABLE.EXE/OUTPUT=TEST_TABLE.EXE VERBS
```

Note that the version number of the output file is one greater than the version number of the input file. If you do not explicitly specify an output file using the /OUTPUT qualifier, CDU replaces your process command table with the modified command table.

1.6 Using Command Language Routines

A program invoked by a command that you have added to your process (or system) command table needs information about the command string that invoked it. The program can obtain this information by calling the appropriate command language routine:

| | |
|----------------|---|
| CLI\$PRESENT | Determines if an entity is present in the command string |
| CLI\$GET_VALUE | Gets the value of the next entity in the command string |
| CLI\$DCL_PARSE | Parses a command string |
| CLI\$DISPATCH | Invokes the routine that corresponds to the verb most recently parsed |

When you use CDU to add a new command, use the CLI\$PRESENT and CLI\$GET_VALUE routines from the program invoked by the command to get information about the command string that called the program.

When you use CDU to create and link an object module that includes a command table, use the CLI\$DCL_PARSE and CLI\$DISPATCH routines to parse the command string and to execute the command. Then use the CLI\$PRESENT and CLI\$GET_VALUE routines within the routines that execute the command.

The CDU Examples section shows two programs that call these routines. For more information about the command language routines, see the *OpenVMS Utility Routines Manual*.

CDU Usage Summary

The Command Definition Utility (CDU) creates, deletes, or changes command definitions in a command table. CDU uses either an existing command table, a file that contains command definitions, or a combination of these, to create a new command table. The output table can be part of an executable image or an object module.

You invoke CDU with the DCL command `SET COMMAND` together with the appropriate qualifiers.

Format

```
SET COMMAND [filespec[, . . . ]]
```

Command Parameter

filespec[, . . .]

Specifies the name of one or more command definition files (default file type `.CLD`). If you specify two or more files, separate them with commas.

Wildcard characters are allowed in the file specification.

Usage Summary

Use the DCL command `SET COMMAND` to invoke CDU. `SET COMMAND` has the following modes:

| | |
|----------------------------------|--|
| <code>SET COMMAND/DELETE</code> | Deletes command definitions from a command table |
| <code>SET COMMAND/OBJECT</code> | Creates an object module from a command definition file |
| <code>SET COMMAND/REPLACE</code> | Adds or replaces definitions in a command table using definitions from a command definition file |

The `/DELETE`, `/OBJECT`, and `/REPLACE` qualifiers establish the various `SET COMMAND` modes and are mutually exclusive; that is, you can use only one of these qualifiers in a command string.

The DCL prompt reappears on your screen when CDU finishes processing the command definition file or table.

By default, `SET COMMAND/DELETE` and `SET COMMAND/REPLACE` modify your process command table and return the modified table to your process. You can modify a different input command table by using the `/TABLE` command qualifier.

Note

You need `CMKRNL` privilege to modify the system command table in `SYS$LIBRARY:DCLTABLES.EXE`.

You can write the command table to an output file by using the `/OUTPUT` command qualifier along with the `/TABLE` qualifier.

`SET COMMAND/OBJECT` creates an object module with the same name as the command definition file unless you specify an alternate file name.

CDU File Statements

This section provides complete information about the statements that can be used in a command definition file. The statements are as follows:

```
DEFINE SYNTAX syntax-name [verb-clause[, ... ]]  
DEFINE TYPE type-name [type-clause[, ... ]]  
DEFINE VERB verb-name [verb-clause[, ... ]]  
IDENT ident-string  
MODULE module-name
```

DEFINE SYNTAX

Defines a syntax change that replaces a command's syntax (as defined in a `DEFINE VERB`, `DEFINE TYPE`, or another `DEFINE SYNTAX` statement). A syntax change allows a verb to use different syntax depending on the parameters, qualifiers, and keywords present in the command string.

`DEFINE` statements that refer to changed syntax are called primary `DEFINE` statements; `DEFINE SYNTAX` statements that define new syntax are called secondary `DEFINE` statements.

When a command string is parsed, its components are scanned from left to right. The string is parsed according to the current definition until CDU encounters an entity that specifies a syntax change. The remainder of the string is parsed using the new definition. DCL does not rescan the entities that appear before the entity that specified the syntax change.

Table 1–2 shows how the `DEFINE SYNTAX` statement modifies the current command definition if an entity specifies a syntax change. After parsing the command string, DCL saves the command definition to determine if any entities in the command string are not allowed. Then, DCL invokes the image or routine specified by the command definition and uses the definition to process `CLI$PRESENT` and `CLI$GET_VALUE` calls.

Table 1–2 How the `DEFINE SYNTAX` Statement Modifies the Primary `DEFINE` Statement

| DEFINE SYNTAX Specifies | Result |
|-------------------------------------|--|
| An image | An image overrides the image in the primary <code>DEFINE</code> statement. DCL invokes the new image after it parses the command string. |
| A routine | A routine overrides the routine in the primary <code>DEFINE</code> statement. DCL invokes the new routine when <code>CLI\$DISPATCH</code> is called. |
| One or more disallows | One or more disallows are used during command parsing and they override disallows in the primary <code>DEFINE</code> statement. This applies to all entities in the command that have not been invalidated by the new syntax definition. |
| No disallows | Disallows from the primary <code>DEFINE</code> statement are used during command parsing. |
| The <code>NODISALLOWS</code> clause | No disallows are permitted, regardless of definitions in the primary <code>DEFINE</code> statement. |

(continued on next page)

CDU File Statements

DEFINE SYNTAX

Table 1–2 (Cont.) How the DEFINE SYNTAX Statement Modifies the Primary DEFINE Statement

| DEFINE SYNTAX Specifies | Result |
|--------------------------------|---|
| One or more parameters | <p>Parameters that were already parsed are not reparsed according to the new definitions. However, parameters to the right of the entity that specified the new syntax are parsed according to the new definitions. DCL uses the new parameter definitions when processing CLI\$PRESENT and CLI\$GET_VALUE calls.</p> <p>Note that, in the DEFINE SYNTAX statement, P1 refers to the first parameter in the command string. To define additional parameters, use the PARAMETER clause in a secondary DEFINE statement to first enter the definitions for the original parameters exactly as they appear in the primary DEFINE statement. Then, enter the definitions for the additional parameters.</p> |
| No parameters | <p>Parameter definitions from the primary DEFINE statement are used when DCL parses the remainder of the command string. DCL also uses these parameter definitions when processing CLI\$PRESENT and CLI\$GET_VALUE calls.</p> |
| The NOPARAMETERS clause | <p>Parameters previously parsed are not reparsed to the new definitions. However, no parameters are allowed when DCL parses entities to the right of the entity that specifies the new syntax. DCL uses the NOPARAMETERS definition when processing CLI\$PRESENT and CLI\$GET_VALUE calls.</p> |
| One or more qualifiers | <p>If any qualifiers have been previously parsed, they are ignored, and DCL issues an informational message. Qualifiers that appear in the command string after the entity specifies the new syntax are parsed according to the new definition. DCL uses the new qualifier definitions when processing CLI\$PRESENT and CLI\$GET_VALUE calls.</p> |

(continued on next page)

Table 1–2 (Cont.) How the DEFINE SYNTAX Statement Modifies the Primary DEFINE Statement

| DEFINE SYNTAX Specifies | Result |
|-------------------------|---|
| No qualifiers | Note that the qualifier that causes the syntax change cannot be retrieved from the CLI routines. Compaq recommends the use of either the IMAGE or ROUTINE clause to determine which syntax is in use. Qualifier definitions from the primary DEFINE statement are used when DCL parses the remainder of the command string. DCL also uses these qualifier definitions when processing CLI\$PRESENT and CLI\$GET_VALUE calls. |
| The NOQUALIFIERS clause | Qualifiers previously parsed are ignored. No qualifiers are allowed when DCL parses entities to the right of the entity that specifies the new syntax. DCL uses the NOQUALIFIERS definition when processing CLI\$PRESENT and CLI\$GET_VALUE calls. |

Format

```
DEFINE SYNTAX syntax-name [verb-clause[, . . . ]]
```

syntax-name

The name of the syntax change. The name is required and must immediately follow the DEFINE SYNTAX statement.

verb-clause[, . . .]

Optional verb clauses that define attributes of the command string.

DEFINE SYNTAX accepts the following verb clauses:

- DISALLOW, NODISALLOWS
- IMAGE
- PARAMETER, NOPARAMETERS
- QUALIFIER, NOQUALIFIERS
- ROUTINE

The following text describes these clauses. Note that, if the syntax list contains only an IMAGE or ROUTINE clause, it affects only the specified clause in the primary DEFINE statement. If the list contains any qualifiers or the NOQUALIFIERS keyword, all qualifiers in the primary DEFINE statement are replaced by the qualifiers in the syntax list. If the syntax list contains neither qualifiers nor the NOQUALIFIERS keyword, the qualifiers in the primary DEFINE statement apply. Similarly, if the syntax list contains any parameter or the NOPARAMETERS keyword, all parameters in the primary DEFINE statement are replaced.

CDU File Statements

DEFINE SYNTAX

DISALLOW expression **NODISALLOWS**

Disallows a command string if the result of the expression is true. The NODISALLOWS clause indicates that all entities and entity combinations are allowed.

The **expression** specifies an entity or a combination of entities connected by operators. Each entity in the expression is tested to see if it is present (true) or absent (false) in a command string. If an entity is present by default but not explicitly provided in the command string, the entity is false.

After each entity is evaluated, the operations indicated by the operators are performed. If the result is true, the command string is disallowed. If the result is false, the command string is valid.

You can specify entities in an expression using an entity name or label, a keyword path, or a definition path. See Section 1.4.4.1 for more information about entities. You can also specify the operators AND, ANY2, NEG, NOT, or OR. See Section 1.4.4.2 for more information about these operators.

IMAGE image-string

Names an image to be invoked by the command. The **image-string** is the file specification (a maximum of 63 characters) of the image DCL invokes when you enter the command. The default device and directory is SYS\$SYSTEM: and the default file type is .EXE.

If you do not specify the IMAGE verb clause and you use SET COMMAND/REPLACE to process the command definition file, the verb name is used as the image name. At run time, DCL searches for an image whose file name is the same as the verb name and whose device and directory names and file type are SYS\$SYSTEM: and .EXE, respectively.

PARAMETER param-name [,param-clause[, . . .]] **NOPARAMETERS**

Can be used to specify up to eight parameters in the command string. The NOPARAMETERS clause indicates that no parameters are allowed.

The **param-name** defines the position of the parameter in the command string. The name must be in the form P n , where n is the position of the parameter. The parameter names must be numbered consecutively from P1 to P8. The name must immediately follow the PARAMETER clause.

The **param-clause** specifies additional characteristics for the parameter. You can use the following parameter clauses:

- DEFAULT
- LABEL=label-name
- PROMPT=prompt-string
- VALUE[(param-value-clause[, . . .])]

DEFAULT indicates that a user-defined parameter keyword is present by default. You should use this clause only if you also use the VALUE clause to indicate that a user-defined keyword must be specified as the parameter value. See the description of the DEFINE TYPE statement for more information on defining a keyword that is present by default.

To designate a default parameter that is not a keyword, use the VALUE(DEFAULT=default-string) clause.

CDU File Statements DEFINE SYNTAX

LABEL=label-name defines a label for referring to a parameter at run time. Specify the label name as a symbol. If you do not specify a label name, the parameter name (P1 through P8) is used as the label name.

PROMPT=prompt-string supplies a prompt string (a maximum of 31 characters) when a parameter is omitted from the command string. If you do not specify a prompt string and a required parameter is missing, DCL uses the parameter name as the prompt string.

When you define more than one parameter but only the first parameter is required, DCL prompts for the first parameter until the user either enters a value or aborts the command with Ctrl/Z. When the user enters a value for the first parameter, DCL prompts for the optional parameters. If the user presses Return without entering a value for an optional parameter, DCL executes the command.

VALUE[(param-value-clause[, . . .])] specifies additional characteristics for the parameter. When you specify parameter value clauses, enclose them in parentheses and separate items with commas.

VALUE accepts the following parameter value clauses:

| | |
|--------------------------------|---|
| CONCATENATE | Indicates that a parameter can be concatenated to another parameter with a plus sign. |
| DEFAULT =default-string | Specifies a default value to be used if a value for the parameter is not explicitly given. The DEFAULT clause and the REQUIRED clause are mutually exclusive. Specify the default string as a character string that does not exceed 94 characters. Do not use this clause to specify a default if the value is a keyword. Specify keyword defaults in the DEFINE TYPE statement and by using the DEFAULT clause. |
| LIST | Permits you to enter a list of parameters separated by commas or plus signs. |
| NOCONCATENATE | Indicates that the parameters cannot be concatenated. |
| REQUIRED | Indicates that the parameter is required. All required parameters must precede optional ones. If you use the REQUIRED clause, you should also specify a prompt string. The REQUIRED clause and the DEFAULT clause are mutually exclusive. |
| TYPE =type-name | Gives either a built-in value type or the name of a DEFINE TYPE statement that defines a list of keywords that can be specified for the parameter. Specify the value type name as a symbol. See Section 1.4.2.1 for more information about built-in value types. |

CDU File Statements

DEFINE SYNTAX

QUALIFIER *qual-name* [,*qual-clause* [, . . .]]

NOQUALIFIERS

Specifies a qualifier that can be included in the command string. You can use the **QUALIFIER** clause up to 255 times in a **DEFINE SYNTAX** statement. The **NOQUALIFIERS** clause indicates that no qualifiers are allowed.

The **qual-name** is the name of the qualifier. Specify the qualifier name as a symbol. The first four characters of the qualifier name must be unique.

The **qual-clause** specifies additional qualifier characteristics. You can use the following qualifier clauses:

- **BATCH**
- **DEFAULT**
- **LABEL=label-name**
- **NEGATABLE, NONNEGATABLE**
- **PLACEMENT=placement-clause**
- **SYNTAX=syntax-name**
- **VALUE[(qual-value-clause [, . . .])]**

BATCH indicates that the qualifier is present by default if the command is used in a batch job.

DEFAULT indicates that the qualifier is present by default in both batch and interactive jobs.

LABEL=label-name defines a label for requesting information about the qualifier at run time. Specify the label name as a symbol. If you do not specify a label name, the qualifier name is used as the label name.

NEGATABLE and **NONNEGATABLE** indicate whether the qualifier can be negated by adding **NO** to the qualifier name. The default is **NEGATABLE**; if you do not specify either **NEGATABLE** or **NONNEGATABLE**, **NO** can be added to the qualifier name to indicate that the qualifier is not present.

PLACEMENT=placement-clause indicates where the qualifier can appear in the command string. **PLACEMENT** accepts the following placement clauses:

| | |
|-------------------|---|
| GLOBAL | Indicates that the qualifier applies to the entire command and can be placed after the verb or after a parameter. This is the default if you do not specify the PLACEMENT clause. |
| LOCAL | Indicates that the qualifier can appear only after a parameter value and that it applies only to that parameter. |
| POSITIONAL | Indicates that the qualifier can appear anywhere in the command string, but the function of the qualifier depends on its position: if the qualifier is used after a parameter value, it applies only to that parameter; if it is used after the verb, it applies to all parameters. |

SYNTAX=syntax-name specifies an alternate syntax definition to be invoked when the qualifier is present. The syntax name must correspond to the name used in a **DEFINE SYNTAX** statement. Specify the syntax name as a symbol.

VALUE[(qual-value-clause[, . . .])] specifies additional characteristics for the qualifier. When you specify qualifier value clauses, enclose the list in parentheses and separate items with commas. If you do not specify any qualifier value clauses, DCL converts letters in qualifier values to uppercase.

VALUE accepts the following qualifier value clauses:

DEFAULT=default-string Specifies a default value to be used if a value for the qualifier is not explicitly given. The **DEFAULT** clause and the **REQUIRED** clause are mutually exclusive. Specify the default string as a character string that does not exceed 94 characters.

Do not use this clause to specify a default if the value is a keyword. Specify keyword defaults in the **DEFINE TYPE** statement and by using the **DEFAULT** qualifier clause.

LIST Indicates that a list of values separated by commas can be specified for the qualifier. This list must be enclosed in parentheses, and the items must be separated by commas. Note that plus signs cannot be used to separate items in a list of qualifier values.

REQUIRED Indicates that the qualifier must have an explicitly specified value. No prompting is performed for a required qualifier value. The **REQUIRED** clause and the **DEFAULT** clause are mutually exclusive.

TYPE=type-name Gives either a built-in value type or the name of a **DEFINE TYPE** statement that defines a list of keywords that can be specified for the parameter. Specify the value type name as a symbol. See Section 1.4.2.1 for more information about built-in value types.

ROUTINE routine-name

Names a routine in syntax. Use the **ROUTINE** clause to create an object module from the command definition file.

The **routine-name** provides the name of the routine to be executed when **CLI\$DISPATCH** is called. Specify the routine name as a symbol.

If you do not specify a routine, the routine from the primary **DEFINE** statement is invoked, if applicable.

Examples

```
1. DEFINE VERB WRITER
    IMAGE "WORK:[JONES]WRITER"
    QUALIFIER LINE, SYNTAX=LINE
    QUALIFIER SCREEN, SYNTAX=SCREEN

    DEFINE SYNTAX LINE
    IMAGE "WORK:[JONES]LINE"
    QUALIFIER NUM
```

CDU File Statements

DEFINE SYNTAX

```
DEFINE SYNTAX SCREEN
    IMAGE "WORK:[JONES]SCREEN"
    QUALIFIER AUDIT
```

This example illustrates a command definition file (WRITER.CLD) containing DEFINE SYNTAX statements that cause syntax changes depending upon the qualifiers specified in the command string. The verb WRITER invokes a text editor (WRITER.EXE). However, you can use the SCREEN and the LINE qualifiers to invoke alternate text editors.

You can add the command definition to your process command table by issuing the following command:

```
$ SET COMMAND WRITER
```

Then you can use the WRITER command to access different text editors. For example, assume you specify the following command:

```
$ WRITER/LINE
```

Here you invoke the LINE editor instead of the default editor (WRITER). Syntax redefinition is done from left to right because parsing of the string is done from left to right. This order means that when you specify two qualifiers that invoke different syntax lists, the leftmost qualifier takes precedence (because it is parsed first).

```
2. DEFINE VERB DISPLAY
    PARAMETER P1, LABEL=ITEM, VALUE(REQUIRED, TYPE=$FILE)
    QUALIFIER SAVE, SYNTAX=SAVE

DEFINE SYNTAX SAVE
    IMAGE "WORK:[NEWMAN]:SAVE_DISPLAY"
    PARAMETER P1, LABEL=ITEM, VALUE(REQUIRED, TYPE=$FILE)
    PARAMETER P2, LABEL=NAME
```

This example shows a syntax change that defines an additional parameter. The command definition file defines the verb DISPLAY. If the DISPLAY command is used without the /SAVE qualifier, then one parameter is required. This parameter indicates the name of the file to be displayed. If the DISPLAY command is used with the /SAVE qualifier, then two parameters are required: the name of the file to be displayed and the name of the file where the display should be saved. Note that you must repeat the definition of P1 in the DEFINE SYNTAX statement.

DEFINE TYPE

Describes the keywords referenced by the VALUE(TYPE=type-name) clause. You can use the VALUE clause in a DEFINE VERB, DEFINE SYNTAX, or DEFINE TYPE statement to indicate predefined values (keywords) for command parameters, qualifiers, or keywords.

Format

```
DEFINE TYPE name [type-clause[, . . . ]]
```

name

The name of the DEFINE TYPE statement. This name must match the name used in the VALUE(TYPE=type-name) clause that references the DEFINE TYPE statement.

type-clause[, . . .]

Defines a keyword that can be used as the value of the entity that referenced the DEFINE TYPE statement. The DEFINE TYPE statement accepts the following type clause:

```
KEYWORD keyword-name [,keyword-clause[,...]]
```

This clause specifies a keyword that can be used as the value type of the entity that references the DEFINE TYPE statement. Repeat the KEYWORD value type clause for each keyword that can be used. You can specify up to 255 keywords in a DEFINE TYPE statement.

The **keyword-name** is the name of the keyword. The optional **keyword-clause** specifies additional keyword characteristics.

You can use the following keyword clauses:

- DEFAULT
- LABEL=label-name
- NEGATABLE, NONNEGATABLE
- SYNTAX=syntax-name
- VALUE[(key-value-clause[, . . .])]

DEFAULT indicates that the keyword is present by default. For this keyword to be recognized as present by default, the parameter, qualifier, or keyword definition that references this DEFINE TYPE statement must also specify the DEFAULT clause.

LABEL=label-name defines a label for referencing the keyword at run time. By default, the keyword name is used as the label name.

NEGATABLE and NONNEGATABLE indicate whether the keyword can be negated by adding NO to the keyword name (the default is NONNEGATABLE). If you do not specify either NEGATABLE or NONNEGATABLE, NO cannot be used to negate the keyword name. Note that this differs from qualifiers, which, by default, are negatable.

SYNTAX=syntax-name specifies an alternate verb definition to be invoked when the keyword is present. The syntax name must match the name used in the corresponding DEFINE SYNTAX statement.

CDU File Statements

DEFINE TYPE

VALUE[(key-value-clause[, . . .])] specifies additional characteristics for the keyword.

VALUE accepts the following keyword value clauses:

| | |
|------------------------|---|
| DEFAULT=default-string | Specifies a default value to be used if a value for the keyword is not explicitly given. The DEFAULT clause and the REQUIRED clause are mutually exclusive. Specify the default string as a character string that does not exceed 94 characters. Do not use this clause to specify a default if the value is a keyword. Specify keyword defaults in the DEFINE TYPE statement and by using the DEFAULT clause with the entity that uses the keyword. |
| LIST | Indicates that a list of values for the keyword can be given. This list must be enclosed in parentheses, and the items must be separated by commas. Note that plus signs cannot be used to separate items in a list of keyword values. |
| REQUIRED | Indicates that the keyword must have an explicitly specified value. No prompting is performed for a required keyword value. If the keyword is specified without a value, an error is automatically issued by DCL. The REQUIRED clause and the DEFAULT clause are mutually exclusive. |
| TYPE=type-name | Symbolically equates either a built-in value type or the name of a DEFINE TYPE statement that defines keywords that can be specified as the keyword value. The TYPE clause cannot be specified if the DEFAULT clause is specified. See Section 1.4.2.1 for more information about built-in value types. |

Examples

```
1. DEFINE VERB DISPLAY
    PARAMETER P1, LABEL=OPTION, PROMPT="What"
    VALUE(REQUIRED, TYPE=DISPLAY_OPTIONS)

DEFINE TYPE DISPLAY_OPTIONS
    KEYWORD ANIMALS, SYNTAX=DISPLAY_ANIMALS
    KEYWORD FLOWERS, SYNTAX=DISPLAY_FLOWERS

DEFINE SYNTAX DISPLAY_ANIMALS
    IMAGE "USER:[JOHNSON]ANIMALS"
    PARAMETER P1, LABEL=OPTION, VALUE(REQUIRED)
    QUALIFIER SMALL
    QUALIFIER LARGE
    QUALIFIER ALL, DEFAULT
```



```
DEFINE SYNTAX DISPLAY FLOWERS  
  IMAGE "USER:[JOHNSON]FLOWERS"  
  PARAMETER P1, LABEL=OPTION, VALUE(REQUIRED)  
  NOQUALIFIERS
```

This example shows how to define keywords that can be specified as parameters for the verb DISPLAY. Each keyword uses its own syntax definition to invoke an image to execute the command.

After you add the command definition to your process command table, you can enter the following DISPLAY commands:

```
$ DISPLAY ANIMALS  
$ DISPLAY FLOWERS
```

In addition, the syntax definition DISPLAY_ANIMALS specifies three qualifiers that can be used only with the command DISPLAY ANIMALS. No qualifiers are allowed with the command DISPLAY FLOWERS.

```
2. DEFINE VERB DRAW  
  QUALIFIER COLOR, VALUE(TYPE=COLOR_NAMES)  
  
  DEFINE TYPE COLOR_NAMES  
    KEYWORD RED  
    KEYWORD BLUE
```

This example shows a verb definition that uses a DEFINE TYPE statement to define keywords that can be used with a qualifier. After you add the command definition for DRAW to your process command table, you can enter the following DRAW commands:

```
$ DRAW/COLOR=RED  
$ DRAW/COLOR=BLUE
```

```
3. DEFINE VERB RANDOM  
  PARAMETER P1, VALUE(TYPE=THINGS), DEFAULT  
  
  DEFINE TYPE THINGS  
    KEYWORD NUMBER, DEFAULT  
    KEYWORD LETTER
```

This example defines a verb, RANDOM. RANDOM accepts a parameter, which must be one of the user-defined keywords NUMBER or LETTER. If a parameter is not specified with the verb RANDOM, then the default is NUMBER.

Note that, for the keyword NUMBER to be present by default, you must use the DEFAULT clause in two places. You must specify DEFAULT when you define the parameter in the DEFINE VERB statement, and you must also specify DEFAULT when defining the NUMBER keyword in the DEFINE TYPE statement.

CDU File Statements

DEFINE VERB

DEFINE VERB

Defines a new command, its parameters, its qualifiers, and the image or routine it invokes.

Format

```
DEFINE VERB verb-name [verb-clause[, . . . ]]
```

verb-name

The name of the command verb. This parameter is required and must immediately follow the DEFINE VERB statement. The first four characters of the verb name must be unique.

verb-clause[, . . .]

Optional verb clauses that define attributes of the command string.

DEFINE VERB accepts the following verb clauses:

- DISALLOW, NODISALLOWS
- IMAGE
- PARAMETER, NOPARAMETERS
- QUALIFIER, NOQUALIFIERS
- ROUTINE
- SYNONYM

The following text describes these verb clauses.

DISALLOW expression

NODISALLOWS

Disallows a command string if the result of the expression is true. The NODISALLOWS clause indicates that all entities and entity combinations are allowed.

The **expression** specifies an entity or a combination of entities connected by operators. Each entity in the expression is tested to see if it is present (true) or absent (false) in a command string. If an entity is present by default but not explicitly provided in the command string, the entity is false.

After each entity is evaluated, the operations indicated by the operators are performed. If the result is true, the command string is disallowed. If the result is false, the command string is valid.

You can specify entities in an expression using an entity name or label, a keyword path, or a definition path. See Section 1.4.4.1 for more information about entities. You can also specify the operators AND, ANY2, NEG, NOT or OR. See Section 1.4.4.2 for more information about these operators.

IMAGE image-string

Names an image to be invoked by the command. The **image-string** is the file specification (a maximum of 63 characters) of the image DCL invokes when you enter the command. The default device and directory is SYS\$SYSTEM: and the default file type is .EXE.

If you do not specify the **IMAGE** verb clause and you use **SET COMMAND/REPLACE** to process the command definition file, the verb name is used as the image name. At run time, DCL searches for an image whose file name is the same as the verb name and whose device and directory names and file type are **SYS\$SYSTEM:** and **.EXE**.

PARAMETER param-name [,param-clause[, . . .]]
NOPARAMETERS

Can be used to specify up to eight parameters in the command string. The **NOPARAMETERS** clause indicates that no parameters are allowed.

The **param-name** defines the position of the parameter in the command string. The name must be in the form **P n** , where n is the position of the parameter. The parameter names must be numbered consecutively from **P1** to **P8**. The name must immediately follow the **PARAMETER** clause.

The **param-clause** specifies additional characteristics for the parameter. You can use the following parameter clauses:

- **DEFAULT**
- **LABEL=label-name**
- **PROMPT**
- **VALUE[(param-value-clause[, . . .])]**

DEFAULT indicates that a user-defined parameter keyword is present by default. You should use this clause only if you also use the **VALUE** clause to indicate that a user-defined keyword must be specified as the parameter value. See the description of the **DEFINE TYPE** statement for more information about defining a keyword that is present by default.

To designate a default parameter that is not a keyword, use the **VALUE(DEFAULT=default-string)** clause.

LABEL=label-name defines a label for referring to a parameter at run time. Specify the label name as a symbol. If you do not specify a label name, the parameter name (**P1** through **P8**) is used as the label name.

PROMPT=prompt-string supplies a prompt string (a maximum of 31 characters) when a parameter is omitted from the command string. If you do not specify a prompt string and a required parameter is missing, DCL uses the parameter name as the prompt string.

When you define more than one parameter but only the first parameter is required, DCL prompts for the first parameter until the user either enters a value or aborts the command with **Ctrl/Z**. When the user enters a value for the first parameter, DCL prompts for the optional parameters. If the user presses **Return** without entering a value for an optional parameter, DCL executes the command.

VALUE[(param-value-clause[, . . .])] specifies additional characteristics for the parameter. When you specify parameter value clauses, enclose them in parentheses and separate items with commas.

VALUE accepts the following parameter value clauses:

CONCATENATE Indicates that a parameter can be concatenated to another parameter with a plus sign.

CDU File Statements

DEFINE VERB

| | |
|------------------------|---|
| DEFAULT=default-string | Specifies a default value to be used if the value for the parameter is not explicitly given. The DEFAULT clause and the REQUIRED clause are mutually exclusive. Specify the default string as a character string that does not exceed 94 characters. Do not use this clause to specify a default if the value is a keyword. Specify keyword defaults in the DEFINE TYPE statement and by using the DEFAULT parameter clause. |
| LIST | Permits you to enter a list of parameters separated by commas or plus signs. |
| NOCONCATENATE | Indicates that the parameters cannot be concatenated. |
| REQUIRED | Indicates that the parameter is required. All required parameters must precede optional ones. If you use the REQUIRED clause, you should also specify a prompt string. The REQUIRED clause and the DEFAULT clause are mutually exclusive. |
| TYPE=type-name | Gives either a built-in value type or the name of a DEFINE TYPE statement that lists keywords for the parameter. Specify the value as a symbol. See Section 1.4.2.1 for more information about built-in value types. |

QUALIFIER qual-name [,qual-clause[, . . .]]

NOQUALIFIERS

Specifies a qualifier that can be included in the command string. You can use the QUALIFIER clause up to 255 times in a DEFINE VERB statement. The NOQUALIFIERS clause indicates that no qualifiers are allowed.

The **qual-name** is the name of the qualifier. The first four characters of the qualifier name must be unique. Specify the qualifier name as a symbol.

The **qual-clause** specifies additional qualifier characteristics. You can use the following qualifier clauses:

- BATCH
- DEFAULT
- LABEL=label-name
- NEGATABLE, NONNEGATABLE
- PLACEMENT=placement-clause
- SYNTAX=syntax-name
- VALUE[(qual-value-clause[, . . .])]

BATCH indicates that the qualifier is present by default if the command is used in a batch job.

DEFAULT indicates that the qualifier is present by default in both batch and interactive jobs.

LABEL=label-name defines a label for requesting information about the qualifier at run time. Specify the label name as a symbol. If you do not specify a label name, the qualifier name is used by default.

NEGATABLE and **NONNEGATABLE** indicate whether the qualifier can be negated by adding **NO** to the qualifier name. The default is **NEGATABLE**; if you do not specify either **NEGATABLE** or **NONNEGATABLE**, **NO** can be added to the qualifier name to indicate that the qualifier is not present.

PLACEMENT=placement-clause indicates where the qualifier can appear in the command string. **PLACEMENT** accepts the following placement clauses:

- | | |
|-------------------|---|
| GLOBAL | Indicates that the qualifier applies to the entire command string and can be placed after the verb or after a parameter. This is the default if you do not specify the PLACEMENT clause. |
| LOCAL | Indicates that the qualifier can appear only after a parameter value and that it applies only to that parameter. |
| POSITIONAL | Indicates that the qualifier can appear anywhere in the command string, but the function of the qualifier depends on its position: if the qualifier is used after a parameter value, it applies only to that parameter; if it is used after the verb, it applies to all parameters. |

SYNTAX=syntax-name specifies an alternate syntax definition to be invoked when the qualifier is present. The syntax name must correspond to the name used in the related **DEFINE SYNTAX** statement. This alternate syntax is useful for commands that invoke different images depending upon the particular qualifiers that are present. Specify the syntax name as a symbol.

VALUE[(qual-value-clause[, . . .])] specifies additional characteristics for the qualifier. When you specify qualifier value clauses, enclose the list in parentheses and separate items with commas. If you do not specify any qualifier value clauses, **DCL** converts letters in qualifier values to uppercase.

VALUE accepts the following qualifier value clauses:

- | | |
|--------------------------------|---|
| DEFAULT =default-string | Specifies a default value to be used if a value for the qualifier is not explicitly given. The DEFAULT clause and the REQUIRED clause are mutually exclusive. Specify the default string as a character string that does not exceed 94 characters. Do not use this clause to specify a default if the value is a keyword. Specify keyword defaults in the DEFINE TYPE statement and by using the DEFAULT qualifier clause. |
| LIST | Indicates a list of values separated by commas can be specified for the qualifier. This list must be enclosed in parentheses, and the items must be separated by commas. Note that plus signs cannot be used to separate items in a list of qualifier values. |

CDU File Statements

DEFINE VERB

| | |
|----------------|--|
| REQUIRED | Indicates that the qualifier must have an explicitly specified value. No prompting is performed for a required qualifier value. The REQUIRED clause and the DEFAULT clause are mutually exclusive. |
| TYPE=type-name | Gives either a built-in value type or a DEFINE TYPE statement that defines a list of keywords that can be specified for the parameter. Specify the value type as a symbol. See Section 1.4.2.1 for more information about built-in value types. |

ROUTINE routine-name

Symbol that specifies a routine the command calls to create an object module from the command definition file.

The **routine-name** provides the name of a routine that is executed when CLI\$DISPATCH is called.

If you do not specify a routine, no default is provided.

SYNONYM synonym-name

Defines a synonym for the verb name. Specify the synonym name as a symbol.

Examples

1. DEFINE VERB ERASE
PARAMETER,P1 VALUE(DEFAULT=DISK3:[JONES]STATS.DAT)

This definition tells the command language interpreter that ERASE is a valid verb and that it takes a parameter. If you do not enter a parameter value, the default is DISK3:[JONES]STATS.DAT.

Because no image name is specified, the verb ERASE invokes the image SYS\$SYSTEM:ERASE.EXE.

2. DEFINE VERB SCATTER
IMAGE "WRKD\$:[MORRISON]SCATTER"
PARAMETER P1, LABEL=INFILE, PROMPT="Input_file?", VALUE(REQUIRED)
PARAMETER P2, LABEL=OUTFILE, PROMPT="Output_file?", VALUE(REQUIRED)
QUALIFIER SLOW, DEFAULT
QUALIFIER FAST
DISALLOW SLOW AND FAST

This example shows a command definition file that defines a new command called SCATTER that invokes the image WRKD\$:[MORRISON]SCATTER.EXE. It has two required parameters, an input file and an output file. It has two mutually exclusive qualifiers, /SLOW and /FAST (the default is /SLOW).

IDENT

Provides identifying information for an object module created from a command definition file.

Format

```
IDENT ident-string
```

ident-string

A string containing identifying information. The string has a maximum length of 31 characters.

Example

```
MODULE COMMAND_TABLE  
IDENT "V04-001"  
DEFINE VERB SPIN  
.  
.  
.
```

This command definition file uses the IDENT statement to identify the object module file.

CDU File Statements

MODULE

MODULE

Provides a name for an object module and for a global symbol that refers to the address of a command table within an image into which the object module is linked.

Format

MODULE module-name

module-name

The **module-name** is used to create a global symbol that refers to the address of the command table within the image into which the object module is to be linked.

By default, CDU uses the object file name specified with the /OBJECT command qualifier. If no object file is explicitly specified, then CDU uses the name of the first command definition file as the module name.

Example

```
$ CREATE TEST.CLD
MODULE TEST_TABLE
DEFINE VERB_SEND
    ROUTINE SEND_ROUT
    PARAMETER P1
.
.
.
DEFINE VERB_SEARCH
    ROUTINE SEARCH_ROUT
    PARAMETER P1
^Z
$ SET COMMAND/OBJECT=TEST.OBJ TEST
$ LINK PROG,TEST
$ RUN PROG
```

TEST.CLD defines two commands (SEND and SEARCH) that call routines in PROG.EXE, a program that uses DCL to parse command strings and execute routines.

The SET COMMAND command creates a command table object module that is linked with the program object module (PROG.OBJ) to produce an image (PROG.EXE) that includes the code for the program and for the command table. TEST_TABLE refers to the address of the command table in the image.

When you run PROG.EXE, it calls DCL parsing routines to parse the command string using the command table in module TEST_TABLE.

CDU Qualifiers

The following pages describe the qualifiers that can be used with the DCL command SET COMMAND. The qualifiers are as follows:

- /ALPHA
- /DELETE
- /LISTING
- /OBJECT
- /OUTPUT
- /REPLACE
- /TABLE
- /VAX

The /DELETE, /OBJECT, and /REPLACE qualifiers indicate SET COMMAND modes; these qualifiers are mutually exclusive.

CDU Qualifiers

/ALPHA

/ALPHA

Causes CDU to create an OpenVMS Alpha object module when used with the /OBJECT qualifier. The default is to create OpenVMS Alpha object modules on OpenVMS Alpha systems and to create OpenVMS VAX object modules on OpenVMS VAX systems.

Format

```
SET COMMAND/ALPHA/OBJECT [=object-filespec] filespec
```

object-filespec

The file specification for the object file. If no file name is specified, default to the name of the first input (command definition) file; the default file type is .OBJ.

filespec

The command definition file to be processed (wildcard characters are allowed). The default type is .CLD.

Example

```
$ SET COMMAND /ALPHA /OBJECT=A TEST  
MODULE TEST_TABLE
```

In this example, the command definition file TEST.CLD is processed and the command table is written as an OpenVMS Alpha object module to a file named A.OBJ.

/DELETE

Used to delete verb names or synonym names from the command table. If a verb name has synonyms, this qualifier deletes the specified verb or synonym name. If any synonyms remain, or if you delete synonyms and the original verb name remains, the remaining names still reference the verb definition.

You can use the /DELETE qualifier to delete a verb in either your process command table or in a command table file specified with the /TABLE qualifier. If you do not use the /TABLE qualifier to specify an alternate command table, the default is to delete verbs from your process command table. If you do not use the /OUTPUT qualifier to specify an output file, the default is to return the modified command table to your process.

You cannot use the /LISTING, /OBJECT, or /REPLACE qualifier with /DELETE.

Format

```
SET COMMAND/DELETE= (verb[, . . . ])
```

verb

A verb or verb synonym to be deleted from the specified command table. If you specify two or more names, separate them with commas and enclose the list in parentheses.

Examples

1. `$ SET COMMAND/DELETE=DO`

In this example, SET COMMAND deletes the verb DO from your process command table.

2. `$ SET COMMAND/DELETE=(PUSH,SHOVE)/TABLE=TEST_TABLE/OUTPUT=NEW_TABLE`

The commands PUSH and SHOVE are deleted from the command table TEST_TABLE.EXE. The /OUTPUT qualifier writes the modified table to the file NEW_TABLE.EXE. If you do not include the /OUTPUT qualifier, CDU uses the modified table to overwrite your process command table.

/LISTING

Controls whether an output listing is created and optionally provides an output file specification for the listing file. A listing file contains a listing of the command definitions along with any error messages. The listing file is similar to a compiler listing.

If you specify the /LISTING qualifier and omit the file specification, output is written to the default device and directory; the listing file has the same name as the first command definition file and a file type of .LIS.

You can use the /LISTING qualifier only in /OBJECT or /REPLACE mode; you cannot create a listing in /DELETE mode. In /OBJECT and /REPLACE modes, the default is /NOLISTING.

Format

```
SET COMMAND/LISTING [=listing-filespec] [filespec[, . . . ]]
```

```
SET COMMAND/NOLISTING
```

listing-filespec

The file specification for the listing file. The default file name is the name of the first command definition file. The default file type is .LIS.

filespec

The name of the command definition file to be processed (wildcard characters are allowed). The default file type is .CLD.

Examples

1. `$ SET COMMAND/LISTING TEST`

In this example, the command definition file TEST.CLD is processed by CDU, and the new verbs are added to your process command table. (By default, SET COMMAND uses /REPLACE mode.) The modified table is returned to your process, and a listing file named TEST.LIS is created.

2. `$ SET COMMAND/LISTING=A TEST`

The command definition file TEST.CLD is processed by CDU, and the verb definitions are added to your process command table. The modified table is returned to your process, and a listing file named A.LIS is created.

3. `$ SET COMMAND/LISTING/OBJECT GAMES`

SET COMMAND is used to create an object module (GAMES.OBJ) that contains the command definitions in GAMES.CLD. The output object module can then be linked with a program. A listing file named GAMES.LIS is created.

/OBJECT

Creates an object module from a command definition file and optionally provides an object file specification. You cannot use the /OBJECT qualifier to create an object module from a command definition that contains the IMAGE clause.

An object module containing a command table can be linked with the object modules from your program. This enables the program to use its own command table for parsing command strings and executing routines.

On OpenVMS VAX systems, the /OBJECT qualifier creates a VAX module by default. Note that you cannot combine VAX modules and Alpha modules in the same object file. For more information, see the description of the /VAX qualifier.

On OpenVMS Alpha systems, the /OBJECT qualifier creates an Alpha module by default. Note that you cannot combine Alpha modules and VAX modules in the same object file. For more information, see the description of the /ALPHA qualifier.

You can specify only one command definition file when you use SET COMMAND/OBJECT.

If you specify the /OBJECT qualifier and omit the file specification, output is written to the default device and directory; the object file has the same name as the input file and a file type of .OBJ.

You cannot use the /DELETE, /OUTPUT, /REPLACE, or /TABLE qualifier with /OBJECT.

Format

```
SET COMMAND/OBJECT [=object-filespec]
```

filespec

object-filespec

The file specification for the object file. If no file name is specified, defaults to the name of the first input (command definition) file; the default file type is .OBJ.

filespec

The command definition file to be processed (wildcard characters are allowed). The default file type is .CLD.

Examples

1. \$ SET COMMAND/OBJECT TEST

In this example, the command definition file TEST.CLD is processed and a new command table is created. This table is written as an object module to a file named TEST.OBJ. (If not explicitly given, the name of the object module defaults to the name of the command definition file with a file type of .OBJ.)

2. \$ SET COMMAND/OBJECT=A TEST

In this example, the command definition file TEST.CLD is processed and the command table is written as an object module to a file named A.OBJ.

/OUTPUT

Controls where the modified command table should be placed. If you provide an output file specification, the modified command table is written to the specified file. If you do not provide an output file specification, the modified command table is placed in your process. The /NOOUTPUT qualifier indicates that no output is to be generated.

You can use the /OUTPUT qualifier only in /DELETE or /REPLACE mode; the default is /OUTPUT with no file specification. You cannot use the /OUTPUT qualifier in /OBJECT mode.

Format

```
SET COMMAND/OUTPUT [=output-filespec] [filespec[, . . . ]]
```

```
SET COMMAND/NOOUTPUT
```

output-filespec

The specification of the output file that contains the edited command table. The default file type is .EXE.

You can specify an output file only when you use the /TABLE=filespec qualifier to describe an input table.

filespec

The name of the command definition file to be processed (wildcard characters are allowed). The default file type is .CLD.

Examples

1. `$ SET COMMAND/OUTPUT TEST`

The file TEST.CLD is processed and the definitions are added to your process command table. The modified table is returned to your process. (The result is the same as if you had issued the command SET COMMAND TEST.)

2. `$ SET COMMAND/TABLE=A/OUTPUT=A TEST`

The definitions from TEST.CLD are added to command table A.EXE. CDU writes the modified table to the new A.EXE, which has a version number one greater than the input table file.

If you use the /TABLE qualifier and do not provide an output file specification, the modified command table replaces your process command table.

3. `$ SET COMMAND/NOOUTPUT TEST`

The definitions from TEST.CLD are added to your process command table, and the modified table is not written anywhere. You can use this command string to test whether a command definition file is written correctly.

/REPLACE

Used to add or replace verbs in the command table.

You can use the /REPLACE qualifier to either modify the process command table or, with the /TABLE qualifier, to modify a command table file.

You cannot use the /REPLACE qualifier with the /OBJECT or /DELETE qualifier. If you do not explicitly specify /DELETE, /OBJECT, or /REPLACE, the default is /REPLACE.

Format

```
SET COMMAND/REPLACE [filespec [, . . . ]]
```

filespec

The file to be processed (wildcard characters are allowed). The default file type is .CLD.

Examples

1. \$ SET COMMAND SCROLL

This command adds the command definitions from the file SCROLL.CLD to your process command table. The /REPLACE, /TABLE, and /OUTPUT qualifiers are present by default. The /REPLACE qualifier indicates /REPLACE mode; the /TABLE qualifier indicates that your process command table is to be modified; and the /OUTPUT qualifier indicates that the modified command table is to be written to your process.

2. \$ SET COMMAND/TABLE/OUTPUT SCROLL

This command adds the command definitions from the file SCROLL.CLD to your process command table and returns the modified table to your process. (The /TABLE and /OUTPUT qualifiers, with no specified files, default to your process command table.) This command is the same as the command SET COMMAND SCROLL.

3. \$ SET COMMAND/TABLE=COMMAND_TABLE/OUTPUT=NEW_TABLE TEST

CDU adds command definitions from TEST.CLD to the command table in the file COMMAND_TABLE.EXE, and the modified command table is written to NEW_TABLE.EXE.

If you use the /TABLE qualifier to provide an input command table, be sure to provide an output file specification. Otherwise, CDU uses the modified command table to replace your process command table.

4. \$ SET COMMAND/TABLE=TEST_TABLE MYCOMS

In this example, the definitions from MYCOMS.CLD are added to the command table in TEST_TABLE.EXE. The modified command table is written to your process and replaces your process command table. You should replace your process command table only if the new command table contains all the commands you need to perform your work. DCL commands copied to your process command table when you logged in are overwritten.

/TABLE

Specifies the command table to be modified. If you specify the /TABLE qualifier and omit the file specification, the current process command table is modified.

Can be used with /DELETE or /REPLACE but not with /OBJECT; the default is /TABLE with no input file specification.

If you include a file specification, the specified command table is modified.

If you use the /TABLE qualifier without the /OUTPUT qualifier, the modified command table replaces your process command table.

Format

```
SET COMMAND/TABLE [=input-filespec]
```

```
[filespec [, . . . ]]
```

```
SET COMMAND/NOTABLE
```

input-filespec

The input file that contains the command table to be edited. The default file type is .EXE.

filespec

The command definition file to be processed (wildcard characters are allowed). The default file type is .CLD.

Examples

1. `$ SET COMMAND/TABLE TEST`

The commands from TEST.CLD are added to your process command table and the results are returned to your process. The /TABLE qualifier with no file specification indicates that your process command table is to be modified. This command is the same as the command SET COMMAND TEST.

2. `$ SET COMMAND/TABLE=A/OUTPUT=B TEST`

CDU adds the command definitions from TEST.CLD to the command table in A.EXE and writes the modified command table to B.EXE.

If you use the /TABLE qualifier to provide an input command table, be sure to provide an output file specification. Otherwise, the modified command table replaces your process command table.

3. `$ SET COMMAND/TABLE=A`

In this example, the command table in A.EXE is written to your process and replaces your process command table. You should replace your process command table only if the new command table contains all the commands you need to perform your work. DCL commands copied to your process command table when you logged in are overwritten.

/VAX

Causes CDU to create an OpenVMS VAX object module when used with the /OBJECT qualifier. The default is to create OpenVMS Alpha object modules on OpenVMS Alpha systems and to create OpenVMS VAX object modules on OpenVMS VAX systems.

Format

```
SET COMMAND/VAX/OBJECT [=object-filespec] filespec
```

object-filespec

The file specification for the object file. If no file name is specified, defaults to the name of the first input (command definition) file; the default file type is .OBJ.

filespec

The command definition file to be processed (wildcard characters are allowed). The default file type is .CLD.

Example

```
$ SET COMMAND/VAX/OBJECT=A TEST
```

In this example, the command definition file TEST.CLD is processed and the command table is written as an OpenVMS VAX object module to a file named A.OBJ.

CDU Examples

Adding a Command to Your Process Command Table

This example shows how to add a command to your process command table and how to use command language routines in the image invoked by the new command.

The following command definition file defines a new verb called SAMPLE:

```
DEFINE VERB SAMPLE
      IMAGE "USERDISK:[MYDIR]SAMPLE"
      PARAMETER P1,LABEL=FILESPEC
      QUALIFIER EDIT
```

To process this command definition file, use the DCL command SET COMMAND:

```
$ SET COMMAND SAMPLE
```

This command string invokes CDU to process the command definition file (SAMPLE.CLD) and to add the verb SAMPLE to your process command table. The modified table is returned to your process.

The following program illustrates a program called SAMPLE.BAS. It uses the CLI\$PRESENT and CLI\$GET_VALUE command language routines to obtain information about a command string parsed by DCL.

```
1   EXTERNAL INTEGER FUNCTION CLI$PRESENT,CLI$GET_VALUE
10  IF CLI$PRESENT('EDIT') AND 1%
    THEN
      PRINT '/EDIT IS PRESENT',A$
20  IF CLI$PRESENT('FILESPEC') AND 1%
    THEN
      CALL CLI$GET VALUE('FILESPEC',A$)
      PRINT 'FILESPEC = ',A$
30  END
```

This source program must be compiled and linked before it can be invoked by a command verb. When you compile and link the source program, the output file (SAMPLE.EXE) contains an executable image.

You can now use the SAMPLE command to invoke the image SAMPLE.EXE, as follows:

```
$ SAMPLE
```

DCL processes this command in the same way it processes the DCL commands provided by Compaq; that is, DCL checks the syntax and then invokes SAMPLE.EXE to execute the command.

You can include in the command string any parameters and qualifiers defined for the SAMPLE command verb. For example, you can enter the following command string:

```
$ SAMPLE MYFILE
```

In this case, you receive the following display on your screen:

```
FILESPEC = MYFILE
```

You can also include the /EDIT qualifier in the command string. For example:

```
$ SAMPLE MYFILE/EDIT
```

In this case, you receive the following display on your screen:

```
/EDIT IS PRESENT
FILESPEC = MYFILE
```

If you include a qualifier that is not accepted by the command verb, you receive a DCL error message. For example:

```
$ SAMPLE MYFILE/UPDATE
%DCL-W-IVQUAL, unrecognized qualifier - check validity, spelling, and placement
  \UPDATE\
```

If you include two or more parameters in the command string for a verb that was defined to accept only one parameter, you receive an error message. For example:

```
$ SAMPLE MYFILE INFILE
%DCL-W-MAXPARAM, too many parameters - reenter command with fewer parameters
  \INFILE\
```

Creating an Object Module Table for Your Program

This example shows how to create an object module table for your program. It also shows how to use command language routines to parse a command string and to invoke the correct program routine.

When you write a command definition file to create an object module table, specify routines (not images) for each command verb. Your program calls these routines when it processes command strings.

The following example illustrates a command definition file called TEST.CLD that defines three verbs: SEND, SEARCH, and EXIT. Each verb invokes a routine in the program USEREXAMP.BAS.

```
MODULE TEST_TABLE
DEFINE VERB SEND
  ROUTINE SEND_COMMAND
  PARAMETER P1, LABEL = FILESPEC
  QUALIFIER EDIT
DEFINE VERB SEARCH
  ROUTINE SEARCH_COMMAND
  PARAMETER P1, LABEL = SEARCH_STRING
DEFINE VERB EXIT
  ROUTINE EXIT_COMMAND
```

Process TEST.CLD by using SET COMMAND with the /OBJECT qualifier to create object module TEST.OBJ:

```
$ SET COMMAND/OBJECT TEST
```

You can then link TEST.OBJ with an object module that was created from your source program.

The following BASIC program, entitled USEREXAMP.BAS, invokes the routines listed in the command table in TEST.OBJ. It uses the command language routines CLI\$DCL_PARSE and CLI\$DISPATCH to parse command strings and to invoke the routine associated with the command. The program also uses CLI\$PRESENT and CLI\$GET_VALUE to obtain information about command strings.

CDU Examples

```
10 SUB SEND COMMAND
   EXTERNAL INTEGER FUNCTION CLI$PRESENT,CLI$GET_VALUE
   PRINT 'SEND COMMAND'
   PRINT ''

20 IF CLI$PRESENT ('EDIT') AND 1%
   THEN
   PRINT '/EDIT IS PRESENT'

30 IF CLI$PRESENT ('FILESPEC') AND 1%
   THEN
   CALL CLI$GET VALUE ('FILESPEC',A$)
   PRINT 'FILESPEC = ',A$

90 SUBEND

100 SUB SEARCH COMMAND
   EXTERNAL INTEGER FUNCTION CLI$PRESENT,CLI$GET_VALUE
   PRINT 'SEARCH COMMAND'
   PRINT ''

110 IF CLI$PRESENT('SEARCH_STRING') AND 1%
   THEN
   CALL CLI$GET VALUE('SEARCH_STRING',A$)
   PRINT 'SEARCH_STRING = ',A$

190 SUBEND

200 SUB EXIT COMMAND
   CALL SYS$EXIT(1% BY VALUE)

290 SUBEND

1  EXTERNAL INTEGER FUNCTION CLI$DCL_PARSE,CLI$DISPATCH
   EXTERNAL INTEGER FUNCTION SEND_COMMAND,SEARCH_COMMAND,EXIT_COMMAND
   EXTERNAL INTEGER TEST_TABLE,LIB$GET_INPUT

2  IF NOT CLI$DCL_PARSE(,TEST_TABLE,LIB$GET_INPUT,LIB$GET_INPUT,'TEST>') AND 1%
   THEN
   GOTO 2

3  PRINT ''
   CALL CLI$DISPATCH
   PRINT ''
   GOTO 2
   END
```

This source program must be compiled before it can be linked with an object module created from the SET COMMAND/OBJECT command. To compile this program, invoke the VAX BASIC compiler:

```
$ BASIC USEREXAMP
```

You now have a USEREXAMP.OBJ file in addition to the original USEREXAMP.BAS source file. Link USEREXAMP.OBJ with TEST.OBJ by entering the following command:

```
$ LINK USEREXAMP,TEST
```

You now have a file containing an executable image (USEREXAMP.EXE). To execute the image, enter the following command:

```
$ RUN USEREXAMP
```

USEREXAMP.EXE displays the following prompt on your screen:

```
TEST>
```

You can now enter any of the commands you defined in TEST.CLD. For example:

```
TEST> SEND
```

The program calls CLI\$DCL_PARSE to parse the command string SEND. SEND is a valid command, so CLI\$DISPATCH transfers control to the SEND_COMMAND routine. This routine displays the following text:

```
SEND COMMAND
```

```
TEST>
```

You can also include a parameter with the SEND command. For example:

```
TEST> SEND MESSAGE.TXT
```

DCL invokes the SEND_COMMAND routine, which displays the following text:

```
SEND COMMAND
```

```
FILESPEC = MESSAGE.TXT
```

```
TEST>
```

You can also enter the /EDIT qualifier with SEND. For example:

```
TEST> SEND/EDIT MESSAGE.TXT
```

```
SEND COMMAND
```

```
/EDIT is present
```

```
FILESPEC = MESSAGE.TXT
```

```
TEST>
```

You can enter other commands that your program accepts. For example:

```
TEST> SEARCH
```

The SEARCH command string invokes a different routine from the one defined by SEND. In this case, the screen displays the following text:

```
SEARCH COMMAND
```

```
TEST>
```

Unlike the SEND command, the SEARCH command accepts no qualifiers. If you attempt to include a qualifier (such as /EDIT) in the SEARCH command string, CLI\$DCL_PARSE signals the following error:

```
%CLI-W-NOQUAL, qualifier not allowed on this command
```

To exit from the USEREXAMP program and return to the DCL command level, issue the EXIT command:

```
TEST> EXIT
```

LIBRARIAN Description

Libraries are files that you can use to store modules of code or text. The DCL LIBRARY command invokes the Librarian utility.

This chapter describes how to use the Librarian utility (LIBRARIAN) to create, access, and maintain libraries on all OpenVMS platforms. To use Librarian (LBR) routines to create and maintain libraries and their modules, see the following documentation:

- *HP OpenVMS Version 8.2 New Features and Documentation Overview*—Describes new LBR routines for Executable and Linking Format (ELF) object libraries and existing routines extended for ELF object libraries (OpenVMS I64 only).
- *OpenVMS Utility Routines Manual*—Describes additional LBR routines that are the same on OpenVMS I64 systems and OpenVMS Alpha systems.

2.1 Types of Libraries

You can use LIBRARIAN to maintain the following types of libraries:

- Object libraries—Contain the object modules of frequently called routines. The OpenVMS Linker searches specified object module libraries when it encounters a reference it cannot resolve in one of its input files. For more information about how the linker uses libraries, see the *HP OpenVMS Linker Utility Manual*.

An object library has a default file type of .OLB and defaults the file type of input files to .OBJ.

- Macro libraries—Contain macro definitions used as input to the assembler. The assembler searches specified macro libraries when it encounters a macro that is not defined in the input file. See the *VAX MACRO and Instruction Set Reference Manual* for information about defining macros on OpenVMS VAX systems. For information on porting VAX MACRO code to an OpenVMS Alpha systems, see *HP OpenVMS MACRO Compiler Porting and User's Guide*. For information on porting code to I64 systems, see *Porting Applications from HP OpenVMS Alpha to HP OpenVMS Industry Standard 64 for Integrity Servers*.

A macro library has a default file type of .MLB and defaults the file type of input files to .MAR.

- Help libraries—Contain modules of help text that provide user information about a program. You can retrieve help text at DCL level by executing the DCL command HELP or, in your program, by calling the appropriate LBR routines. For information about creating help modules for insertion into help libraries, see Section 2.5.

A help library has a default file type of .HLB and defaults the file type of input files to .HLP.

- Text libraries—Contain sequential record files that you want to retrieve as data for a program. For example, program source code can be stored in text libraries. Each text file inserted into the library corresponds to one library module. Your programs can retrieve text from text libraries by calling the appropriate LBR routines.

LIBRARIAN Description

A text library has a default file type of .TLB and defaults the file type of input files to .TXT.

- Shareable image libraries—Contain the symbol tables of shareable images used as input to the linker. For information about how to create a shareable image library, see Section 2.4.

A shareable image library has a default type of .OLB and defaults the file type of input files to .EXE.

You can create library files that do not have the default file type. For example, you can create the object library LIB.xxx by entering the following:

```
$ LIBRARY/CREATE/OBJECT LIB.xxx *.obj
```

You can then access the object library by entering the following:

```
$ LIBRARY/LIST LIB.xxx
```

Table 2–1 shows the libraries that are created by the Librarian utility for each OpenVMS platform:

Table 2–1 Libraries Created by OpenVMS Platform

| OpenVMS VAX | OpenVMS Alpha | OpenVMS I64 |
|-----------------------------------|---------------------------------|--------------------|
| VAX object | Alpha object | I64 object |
| VAX sharable image | Alpha sharable image | I64 sharable image |
| Alpha object ¹ | VAX object ¹ | |
| Alpha sharable image ² | VAX sharable image ² | |
| Macro | Macro | Macro |
| Text | Text | Text |
| Help | Help | Help |

¹Use /ALPHA qualifier to create and manipulate Alpha object and sharable image libraries.

²Use /VAX qualifier to create and manipulate VAX object and sharable image libraries.

2.2 Structure of Libraries

Every library contains a library header that describes the contents of the library; for example, its type, size, version number, creation date, and number of indexes.

Similarly, each module in the library has a module header that contains information about the module, including its type, attributes, and date of insertion into the library.

All libraries contain an index called the module name table (MNT); the keys in the MNT are the names of the modules in the library. Object module libraries also contain an index called the global symbol table (GST); the keys in the GST are the names of the symbols associated with each of the library modules.

For I64 systems, these symbols also include Unix-style weak symbol definitions and Group symbol definitions.

Note that the MNT catalogs modules by module name, rather than by the name of the input file that contained the inserted module. The only exception to this procedure occurs with text libraries, for which the file name of the input file containing the text automatically becomes the module name (unless you use the /MODULE qualifier).

2.3 Character Case of Library Keys

The character case of module names and symbols in libraries depends on the library type:

- Help libraries—Module names remain in the format they were entered; that is, individual uppercase and lowercase characters are preserved. However, a second, identically spelled module name (but of a different or mixed character case) to the same library replaces the previous module name, and character case is ignored for match operations. For example, *help Sample* and *help SAMPLE* access the same module.
- Object libraries — Module names and symbol names are in the format in which they were entered. Match operations require the character case to be identical. For example, for *SAMPLE*, you must enter *SAMPLE*, not *Sample* or *sample*.
- Text and macro libraries — By default, all module names are converted to uppercase characters. For example, *Sample* becomes *SAMPLE*. Likewise, for match operations, either *Sample* or *sample* matches *SAMPLE*.

You can override this default behavior by using the `CASE_SENSITIVE` option to the `/CREATE` qualifier. If you specify `CASE_SENSITIVE:YES`, module names remain in the format they were entered, individual uppercase and lowercase characters are preserved, and match operations require the character case to be identical.

To use the default behavior for macro and text libraries, do not include the `CASE_SENSITIVE` option with the `/CREATE` qualifier, or specify `CASE_SENSITIVE:NO`.

The `CASE_SENSITIVE` option works only for macro and text libraries. If you try to use it for other library types, you will get an error message and the library creation operation will abort (no library is created).

2.4 Shareable Image Libraries

A shareable image library or ELF sharable image library is made up of only the symbol tables of shareable images, which serve as input to the linker. To create a shareable image library, use the `LIBRARY` command with the `/SHARE` qualifier, as follows:

```
$ LIBRARY/CREATE/SHARE MYSHARLIB MYSHRIMG1,MYSHRIMG2,SHRIMG3
```

You can then specify the library in the `LINK` command exactly as if it were an object library.

```
$ LINK/MAP/FULL MYPROG, MYSHARLIB/LIBRARY
```

The linker includes in the link operation whatever shareable images are needed from references to `MYSHARLIB`.

To explicitly include a shareable image, use the `/INCLUDE` qualifier.

```
$ LINK/MAP/FULL MYPROG, MYSHARLIB/INCLUDE=(MYSHRIMG1)/LIBRARY
```

For each shareable image found that either contains a necessary symbol or was specifically requested with the `/INCLUDE` qualifier, the linker looks up the image file (default file type is `.EXE`) and processes it as if it had been specified in an options file.

LIBRARIAN Description

Unless the search is disabled with the `/NOSYSSHR` qualifier, the linker also searches the library `SYS$LIBRARY:IMAGELIB.OLB` after processing any user default libraries (`LNK$LIBRARY`). Modules found in `IMAGELIB.OLB` are opened with a default file specification of `SYS$LIBRARY:.EXE`.

The default file type for the `LIBRARY/SHARE` command is `.OLB` for the shareable image symbol table library and `.EXE` for the input shareable image files.

`LIBRARIAN` uses the `GSMATCH` identification numbers (IDs) of the shareable image as the module ID in the library. This provides a convenient way to verify that the shareable image information in the library matches the shareable image information contained in a map file from a link operation.

Note that a module inserted into a shareable image library contains only module header information, which is extracted from the shareable image. Consequently, although it is not an invalid action, there is little reason to extract modules from a shareable image library.

2.5 Help Libraries

Help text is a convenient means of providing specific information about a program to an interactive user. The help text is stored as modules in help libraries. You can access the help modules by using the `DCL` command `HELP` or by calling the appropriate `LBR` routines (described in the *OpenVMS Utility Routines Manual*). In this way, a user can quickly retrieve relevant information about how to use your program.

You create help libraries the same way you create object, macro, and text libraries, using the `LIBRARY/CREATE` command. However, before you can insert modules into a help library, you must format the input file so that `LIBRARIAN` can catalog its individual modules. Section 2.5.1 and Section 2.5.2 describe how to create input files containing help modules.

2.5.1 Creating Help Files

The input files that you insert into help libraries are text files that you build with a program or a text editor. Each input file can contain one or more help modules. A help module is made up of the lines of help text that relate to the same topic, or key.

Each module within a help library contains a group of related keys, or topics, numbered key 1 through key 9. Each key represents a level within the hierarchy of the module. The key-1 name identifies the main topic of help information; for example, the name of a command in your program that requires explanation. The key-2 through key-9 names identify subtopics that are related to the key-1 name; for example, the command's parameters or qualifiers or both. This organization enables users of your program to find general information describing how to use the command and then to select subtopics that provide additional information about the command's parameters and qualifiers. The maximum length of a key-1 name is determined by the key size option of the `/CREATE` qualifier.

Index keywords remain in the format they were entered, that is, the character case is unchanged. A second keyword to the same library, identically spelled but of a different or mixed character case, replaces the previous preserved keyword. Character case is ignored for match operations. For example, *help Sample* and *help SAMPLE* access the same module.

The key names for help topics and subtopics can include any printable ASCII characters except those used by LIBRARIAN as either delimiters (space, horizontal tab, and comma) or comments (exclamation point).

HP recommends that you restrict key names to the following characters:

- Uppercase and lowercase letters (A,a,B,b . . . Z,z)
- Digits (0,1,2 . . . 9)
- Dollar sign (\$)
- Underscore (_)
- Hyphen (-)

HP also recommends that you avoid—especially as the first character of a key name—certain characters that have special meaning to LIBRARIAN retrieval routines. If you use these characters in key names, you might not be able to specify them explicitly for retrieval.

The characters you should not use are as follows:

- Asterisk (*)
- Percent sign (%)
- Ellipsis (...)
- At sign (@)
- Slash (/)
- Question mark (?)
- Left parenthesis (() used as a first character
- Apostrophe (') and quotation marks (")

If a key contains any of these characters, you might be able to retrieve its help text by abbreviating the key to avoid the special characters or by using wildcard characters in their place. For information about using wildcard characters, see the *OpenVMS User's Manual*.

Also, note that you cannot abbreviate your retrieval key if it contains wildcard characters.

2.5.2 Formatting Help Files

Each line in a help module consists of the key number in the first column, followed by the name of the key. The subtopic lines that follow (key 2 through key 9) consist of the subkey number followed by the name of the subkey. For example, a help module for a command might have the following two key lines:

```
1 Command name
  .
  .
  .
  help text
  .
  .
  .
2 Parameters
```

Each help source file can contain several modules. LIBRARIAN recognizes a group of key-1 and subkey lines and their associated text as a module. A module is terminated either by another key-1 line or by an end-of-file record.

LIBRARIAN Description

A help source file has the following format:

```
1 key-1 name
.
.
.
help text
.
.
.
2 key-2 name
.
.
.
help text
.
.
.
n key-n name
.
.
.
1 key-1 name
```

LIBRARIAN stores the key-1 name in its module name table; therefore, the name of the module is the same as the key-1 name. The subsequent numbers in the first column indicate that the line is a subkey. A module can have several subkeys with the same number. For example, a help module describing a command might have the following key-2 lines:

```
2 parameters
2 arguments
```

You can insert comments anywhere in a module. When LIBRARIAN encounters an exclamation point as the first character on a line, it assumes that the line consists of comments. Comment lines that follow a key-1 line are included in the module. However, when your program retrieves help text, LIBRARIAN does not display the comments.

The help text can be any length; the only restriction to the text is that it cannot contain a number or a slash (/) in the first column of any line. A number in the first column of a line indicates that the line is a key. A slash in the first column indicates a qualifier line.

A qualifier line is similar to a key line, except that LIBRARIAN returns a list of all the qualifier lines when you request help either on a key-1 topic or on the key containing the qualifiers (usually a key-2 topic named “Qualifiers”). Therefore, if your help module describes a command that has qualifiers, LIBRARIAN provides a list of all the command’s qualifiers whenever you request help on the command.

2.5.3 Help Text Example

The help module in Example 2–1 shows the organization of some of the help text for the DCL command LIBRARY.

Example 2–1 Help Text for LIBRARY Command

```
1 LIBRARY
  Invokes the Librarian utility to create, modify, or describe an
  object, macro, help, text, or shareable image library.

  Format:
    LIBRARY library-file-spec [input-file-spec[,...]]
2 Command Parameters
  library-file-spec
    Specifies the name of the library you want to create or modify.
    If the file specification does not include a file type, the LIBRARY
    command assumes a default type of .OLB, indicating an object library.
  input-file-spec[,...]
    Specifies the names of one or more files that contain modules you
    want to insert or replace in the specified library.
    If you specify more than one input file, separate the file
    specifications with commas. The input-file-spec parameter is
    required when you specify /REPLACE, which is the LIBRARY command's
    default operation, or /INSERT, which is an optional qualifier.
    When you use the /CREATE qualifier to create a new library, the
    input-file-spec parameter is optional. If you include an input file
    specification with /CREATE, the LIBRARY command first creates a new
    library and then inserts the contents of the input files into the
    library.
2 Command Qualifiers
/BEFORE
/BEFORE[=time]
  Used in conjunction with the /LIST qualifier to specify that only
  those modules dated earlier than a particular time be listed. You
  can specify an absolute time or a combination of absolute and delta
  times.
  If you omit the /BEFORE qualifier, all modules are listed regardless
  of date. If you specify /BEFORE without a date or time, all modules
  created before today are listed by default.
/COMPRESS
/COMPRESS[=(option[,...])]
  Recovers space that had been occupied by modules deleted from the
  library. When you specify /COMPRESS, the LIBRARY command by
  default creates a new version of the library in your current default
  directory. You can use options to the /COMPRESS qualifier to make
  some specifications in the new version of the library different from
  the original library.
```

(continued on next page)

LIBRARIAN Description

Example 2–1 (Cont.) Help Text for LIBRARY Command

```
/CREATE
/CREATE[=(option[,...])]

Creates a new library. When you specify /CREATE, you can optionally
specify a file or a list of files that contains modules to be placed
in the library.

By default, the LIBRARY command creates an object module library;
specify /SHARE, /MACRO, /HELP, or /TEXT to change the default
library type.
.
.
.
```

2.5.4 Retrieving Help Text

You can retrieve help text at DCL level by using the DCL command `HELP` or, in your program, by calling the appropriate Librarian utility (LBR) routines (as described in the *OpenVMS Utility Routines Manual*).

By default, the `HELP` command retrieves help text from the system help library `SYS$HELP:HELPLIB.HLB` and from user help libraries associated with the logical names `HLP$LIBRARY`, `HLP$LIBRARY_1`, `HLP$LIBRARY_2`, and so forth. Using the `/LIBRARY` qualifier with the `HELP` command lets you search a library other than the default libraries. For more information, see the description of the `HELP` command in the *HP OpenVMS DCL Dictionary*.

When you retrieve help text, you specify the key-1 topic followed by any subtopics that contain appropriate help information. `LIBRARIAN` returns the help text associated with the key path you specify. For example, the help text for the `LIBRARY` command is stored in the default system help library; thus, to retrieve the `LIBRARY` command's key-1 help information, you would enter the DCL command `HELP LIBRARY`. `LIBRARIAN` would return the associated help text, followed by the message "Additional information available:" and a list of all the key-2 names in the module. In this case, `LIBRARIAN` also returns a list of all the qualifiers specified in the qualifier lines. Example 2–2 displays the text returned by the `HELP LIBRARY` command.

Example 2–2 HELP LIBRARY Display

```
LIBRARY

Invokes the Librarian utility to create, modify, or describe an
object, macro, help, text, or shareable image library.

Format:

LIBRARY library-file-spec [input-file-spec[,...]]

Additional information available:

Command_Parameters  /ALPHA    /BEFORE    /COMPRESS  /CREATE
/CROSS_REFERENCE  /DATA     /DELETE    /EXTRACT   /FULL      /GLOBALS
/HELP             /HISTORY  /INSERT    /LIST      /LOG       /MODULE
/NAMES           /OBJECT   /ONLY      /OUTPUT    /REMOVE    /REPLACE
/SELECTIVE_SEARCH /SHARE    /SINCE     /SQUEEZE   /TEXT     /VAX
/WIDTH
```

LIBRARIAN Description

Note that you cannot retrieve the key-2 level “Parameters” by entering HELP PARAMETERS. LIBRARIAN searches for a subkey only after finding the higher level keys. In other words, if you want to retrieve key-3 text, you have to specify the key-1 and key-2 lines that form a path to the key-3 line.

Also note that you can provide information about a qualifier that has more than one form by associating two or more qualifier lines with the same help text. That is, the text associated with the qualifiers follows the two or more qualifier lines. For example:

```
$ HELP LIBRARY/GLOBALS
```

```
LIBRARY
```

```
  /GLOBALS
```

```
    /GLOBALS
```

```
    /NOGLOBALS
```

```
    Controls, for object module libraries, whether the names of global symbols in modules being inserted in the library are included in the global symbol table.
```

```
    By default, the LIBRARY command places all global symbol names in the global symbol table. Use /NOGLOBALS if you do not want the global symbol names included in the global symbol table.
```

When LIBRARIAN successfully searches the key path to the requested key, it displays all the key names in that path, followed by the help text associated with the last specified key. For example:

```
$ HELP LIBRARY/HELP
```

```
LIBRARY
```

```
  /HELP
```

```
    Indicates that the library is a help library. When you specify the /HELP qualifier, the library file type defaults to .HLB and the input file type defaults to .HLP.
```

If you try to retrieve help text for a key that is not in the module name table, LIBRARIAN issues a message. For example:

```
$ HELP FIRE
```

```
Sorry, no documentation on FIRE
```

```
Additional information available:
```

```
This message is followed by a list of all the module names in the module name table.
```

If you have correctly specified the key-1 line but have requested a subkey that does not exist, LIBRARIAN issues a message. For example:

```
$ HELP LIBRARY/FIRE
```

```
Sorry, no documentation on LIBRARY/FIRE
```

```
Additional information available:
```

```
Parameters Command Qualifiers
```

```
/BEFORE /COMPRESS
```

```
  .  
  .  
  .
```

LIBRARIAN Description

The message includes a list of all the subkeys associated with the last key that was specified correctly.

2.6 Using the Librarian Utility to Save Disk Space

You can save disk space by using the Librarian utility to reduce data files. To save disk space, create a library, copy the data files you want to reduce into the library, and then use the `LIBRARY/DATA=REDUCE` command to reduce the size of library. When you subsequently want to use the files in their expanded form, you simply extract the data files and they will be expanded automatically. Because data expansion takes time, leave frequently used libraries in their expanded format to increase access performance.

Large, infrequently accessed files are good candidates for this method when you do not want to write a program that uses the callable interface to reduce and expand data files.

Note

For I64 systems, HP strongly recommends that DCX data-reduced ELF object libraries first be expanded before performing Linker operations.

See the description of the `/DATA` qualifier for more information.

2.7 Librarian Utility (LBR) Routines

Programs can call Librarian utility (LBR) routines to do the following:

- Initialize a library
- Open a library
- Look up a key in a library
- Insert a new key in a library
- Return the names of the keys
- Delete a key and its associated data
- Read and write information

For VAX and Alpha systems, the *OpenVMS Utility Routines Manual* describes in detail each LBR routine. For information about LBR routines on I64 systems, see the *HP OpenVMS Version 8.2 New Features and Documentation Overview*.

LIBRARIAN Usage Summary

The Librarian utility (LIBRARIAN) gives you easy access to libraries. Libraries are files in which you can store frequently used modules of code or text.

You can use the DCL command LIBRARY (or the LBR routines) to create a library, maintain the modules in a library, or display information about a library and its modules.

Note that libraries are files, so you can use DCL commands to manipulate libraries in their entirety; for example, you can use the DELETE, COPY, and RENAME commands to delete, copy, and rename libraries. For more information about file maintenance, see the *HP OpenVMS DCL Dictionary*.

Format

```
LIBRARY library-file-spec [input-file-spec[,...]]
```

Command Parameters

library-file-spec

The name of the library you want to create or modify. This parameter is required. If you do not specify a library file, you are prompted for one, as follows:

```
_Library:
```

No wildcard characters are allowed in the library file specification.

If the file specification does not include a file type and if the command string does not indicate a library type, the LIBRARY command assumes an object library type and a default file type of .OLB. You can change the default library file type by specifying the appropriate qualifier, as follows:

| Qualifier | Default Library File Type |
|-----------|---------------------------|
| /HELP | .HLB |
| /MACRO | .MLB |
| /OBJECT | .OLB |
| /TEXT | .TLB |
| /SHARE | .OLB |

input-file-spec[,...]

The names of one or more files that contain modules you want to insert into the specified library. If you specify more than one input file, separate the file specifications with commas.

The input file specification is required when you specify /REPLACE, which is the LIBRARY command's default operation, or /INSERT, which is an optional qualifier. If you do not specify an input file when you use these qualifiers, you are prompted for it, as follows:

```
_File:
```

LIBRARIAN Usage Summary

When you use the `/CREATE` qualifier to create a new library, the input file specification is optional. If you include an input file specification with the `/CREATE` qualifier, LIBRARY first creates a new library and then inserts the contents of the input files into the library.

Note that the `/EXTRACT` qualifier does not accept an input file specification.

If any file specification does not include a file type and if the command string does not indicate one, LIBRARY assumes a default file type of `.OBJ`, designating an object file. You can control the default file type by specifying the appropriate qualifier, as follows.

| Qualifier | Default Input File Type |
|----------------------|-------------------------|
| <code>/HELP</code> | <code>.HLP</code> |
| <code>/MACRO</code> | <code>.MAR</code> |
| <code>/OBJECT</code> | <code>.OBJ</code> |
| <code>/TEXT</code> | <code>.TXT</code> |
| <code>/SHARE</code> | <code>.EXE</code> |

Note also that the file type you specify with the library file specification determines the default file type of the input file specification, provided that you do not specify the `/CREATE` qualifier. For example, if the library file type is `.HLB`, `.MLB`, `.OLB`, or `.TLB`, the input file type default will be `.HLP`, `.MAR`, `.OBJ`, or `.TXT`, respectively. (If you specify the `/CREATE` qualifier and you are not creating an object library, you must use the appropriate file type qualifier.)

Wildcard characters are allowed in the input file specifications.

Usage Summary

The DCL command LIBRARY invokes the Librarian utility. After the operations specified by LIBRARY have completed, the Librarian utility exits.

If you use the `/LIST` qualifier to request information about a library, the output is directed to the file specification associated with `/LIST` or, if you do not supply a file specification, to `SYS$OUTPUT`.

LIBRARIAN Qualifiers

When using LIBRARY, you can specify qualifiers that request more than one function in a single command, with some restrictions. Generally, you cannot specify multiple qualifiers that request incompatible functions. The qualifiers that perform library functions, related qualifiers, and qualifier incompatibilities are summarized in Table 2–2.

Table 2–2 LIBRARY Command Qualifier Compatibilities

| Qualifier | Related Qualifiers | Incompatible Qualifiers |
|----------------------|---|---|
| /COMPRESS | /OUTPUT | /CREATE, /EXTRACT |
| /CREATE ¹ | /SQUEEZE, ² /GLOBALS, ³ /SELECTIVE_SEARCH ³ | /COMPRESS, /EXTRACT |
| /CROSS_REFERENCE | /ONLY | /EXTRACT, /LIST |
| /DATA | /COMPRESS | — |
| /DELETE | — | /EXTRACT |
| /EXTRACT | /OUTPUT | /COMPRESS, /CREATE, /DELETE, /INSERT, /LIST, /REMOVE, /REPLACE |
| /INSERT | /SQUEEZE, ² /GLOBALS, ³ /SELECTIVE_SEARCH ³ | /EXTRACT |
| /LIST | /FULL, /NAMES, ³ /ONLY, /HISTORY, /BEFORE, /SINCE | /EXTRACT, /CROSS_REFERENCE |
| /REMOVE ³ | — | /EXTRACT |
| /REPLACE | /SQUEEZE, ² /GLOBALS, ³ /SELECTIVE_SEARCH ³ | /EXTRACT |
| /MODULE ⁴ | /TEXT | /EXTRACT, /DELETE, /REMOVE |

¹The /CREATE, /INSERT, and /REPLACE qualifiers are compatible; however, if you specify more than one, /CREATE takes precedence over /INSERT, and /INSERT takes precedence over /REPLACE. The related qualifiers for /CREATE are applicable only if you enter one or more input files.

²This qualifier applies only to macro libraries.

³This qualifier applies only to object libraries and shareable image libraries.

⁴This positional qualifier applies only to text libraries.

Note that all the qualifiers are command qualifiers except for /MODULE, which is a positional qualifier that modifies the input file specification parameter.

LIBRARIAN Qualifiers

/ALPHA (VAX and Alpha only)

/ALPHA (VAX and Alpha only)

Directs LIBRARIAN to work with an OpenVMS Alpha object library when used with the /OBJECT qualifier or to work with an OpenVMS Alpha shareable image library when used with the /SHARE qualifier. When used with the /CREATE qualifier, LIBRARIAN creates an OpenVMS Alpha library of either an object or shareable image type depending whether /OBJECT or /SHARE is specified.

The default is /ALPHA on OpenVMS Alpha systems and /VAX on OpenVMS VAX systems. The OpenVMS I64 Librarian does not accept this qualifier because the I64 Librarian works exclusively with I64 libraries.

Format

/ALPHA

Description

The /ALPHA qualifier is used to create and manipulate OpenVMS Alpha object and shareable image libraries. Because the formats of macro, help, and text libraries are identical on both system architectures, using the /ALPHA qualifier with the /MACRO, /TEXT, and /HELP qualifiers has no effect.

Note

You cannot have both OpenVMS Alpha and OpenVMS VAX object modules in one object library, nor can you have OpenVMS Alpha and OpenVMS VAX shareable images in the same shareable image library.

Examples

1. `$ LIBRARY/ALPHA/CREATE TESTLIB ERRMSG.OBJ,STARTUP.OBJ`

This LIBRARY command creates an OpenVMS Alpha object library named TESTLIB.OLB and places the files ERRMSG.OBJ and STARTUP.OBJ as modules in the library.

2. `$ LIBRARY/ALPHA/SHARE/CREATE SHARELIB.OLB`

This LIBRARY command creates an OpenVMS Alpha shareable image library called SHARELIB.OLB.

/BEFORE

Specifies that only those modules inserted earlier than a particular time be listed.

Format

/BEFORE[=time]

time

Limits the modules to be listed to those inserted in the library before a specified time.

You can specify an absolute time or a combination of absolute and delta times. For details about specifying times, see the *HP OpenVMS DCL Dictionary*.

Description

This qualifier is used with the /LIST qualifier. If you omit the /BEFORE qualifier, you obtain all the modules regardless of the dates. If you specify /BEFORE without a date or time, the default is to provide the modules inserted before today.

Example

```
$ LIBRARY/LIST/BEFORE=15-APR-:15 MATHLIB
```

This LIBRARY command lists the modules that were inserted into MATHLIB.OLB before 3 p.m. on April 15.

LIBRARIAN Qualifiers /COMPRESS

/COMPRESS

Recovers space that was occupied by modules deleted from the library. When you specify /COMPRESS, LIBRARY creates a new library. You can use options to the /COMPRESS qualifier to make some specifications in the new version of the library different from the original library.

Format

/COMPRESS[=(option[,...])]

option

An option that alters the size or format of the library, overriding the values specified when the library was created. Options are listed in the Description section.

Description

When you specify /COMPRESS, LIBRARY creates a new library. By default, the new library is created in your current default directory and has the same file name as the existing library and a file type that is the default for the type of library created. You can use the /OUTPUT qualifier to specify an alternate file specification for the compressed library.

Specify one or more of the following options to alter the size or format of the library, overriding the values specified when the library was created (for the default values, see the description of the /CREATE qualifier):

- | | |
|-----------|--|
| BLOCKS:n | Specifies the number of 512-byte blocks to be allocated for the library. By default, LIBRARY allocates 100 blocks for a new library. |
| GLOBALS:n | Specifies the maximum number of symbols the library can contain initially. By default, LIBRARY sets a maximum of 512 symbols for an object module library. (Macro, help, and text libraries do not have a symbol directory; therefore, the maximum for these libraries defaults to 0.) |
| HISTORY:n | Specifies the maximum number of library update history records that the library is to maintain. The maximum number of library update records you can specify is 32,767. The default is 20. |
| KEEP | Copies library update history records and any additional user data in the module header to the compressed library. |

- KEYSIZE:n** Specifies the maximum name length of modules or symbols.
On VAX systems, LIBRARY assigns default name lengths of 15 characters for help modules, 31 characters for modules in object or macro libraries, and 39 characters for modules in text or shareable image libraries. The maximum length you can specify for these names is 128 characters.
Also on VAX systems, when you specify a key size value, remember that the MACRO compiler and the linker do not accept module names or global symbol names in excess of 31 characters.
On Alpha systems, LIBRARY assigns default name lengths of 15 characters for help modules, 31 characters for modules in macro libraries, 39 characters for modules in text libraries, and 128 characters for modules in object or shareable image libraries. The maximum length you can specify for these names is 128 characters.
Also on Alpha systems, when you specify a key size value, remember that the MACRO compiler does not accept module names and global symbol names in excess of 31 characters, and the linker does not accept module names in excess of 31 characters or global symbol names in excess of 64 characters.
On I64 systems, LIBRARY assigns default name lengths of 15 characters for help modules, 31 characters for modules in macro libraries, 39 characters for modules in text libraries, and 1024 characters for modules in object or shareable image libraries. The maximum length you can specify for these names is 1024 characters.
- MODULES:n** Specifies the maximum number of modules the library can initially contain. By default, LIBRARY sets an initial maximum of 128 modules for all library types.
A library's size can grow past its initial allocation. However, for optimum performance, it is best to allocate the maximum number of modules you expect to use.
- VERSION:n** On VAX systems, specifies that the library is to be stored in VMS Version 2.0 library format, if *n* is 2; or VMS Version 3.0 library format, if *n* is 3. On Alpha and I64 systems, this parameter is ignored.

If you specify more than one option, separate them with commas and enclose the list in parentheses.

Example

```
$ LIBRARY/COMPRESS=(KEYSIZE:40,MODULES:80)/TEXT SOURCE
```

This LIBRARY command creates a new version of the text library SOURCE.TLB. Space left after modules were deleted from the old version is recovered in the new version. The new version can contain up to 80 modules; the maximum length of module names in the new version is 40.

LIBRARIAN Qualifiers /CREATE

/CREATE

Requests the DCL command LIBRARY to create a new library. When you specify /CREATE, you can optionally specify a file or a list of files that contains modules to be placed in the library.

Format

/CREATE[=(option[,...])]

option

An option that overrides the system defaults to control the size or format of the library. Options are listed in the Description section.

Description

By default, the /CREATE qualifier creates an object module library. To indicate that the library is a macro, help, text, or shareable image library, specify /MACRO, /HELP, /TEXT, or /SHARE.

On OpenVMS VAX systems, the /CREATE qualifier creates a VAX library by default when used to create object and shareable image libraries. Note that you cannot have VAX modules and Alpha modules in the same library. For more information, see the description of the /VAX (VAX and Alpha only) qualifier.

On OpenVMS Alpha systems, the /CREATE qualifier creates an Alpha library by default when used to create object and shareable image libraries. Note that you cannot have Alpha modules and VAX modules in the same library. For more information, see the description of the /ALPHA qualifier.

On OpenVMS I64 systems, the /CREATE qualifier creates an ELF library when used to create object and shareable image libraries.

Specify one or more of the following options to override the system defaults:

- | | |
|---------------------------------|---|
| BLOCKS:n | Specifies the number of 512-byte blocks to be allocated for the library. By default, LIBRARY allocates 100 blocks for a new library. |
| CASE_ SENSITIVE: [YES/NO] | Specifies whether key operations on macro or text libraries are case sensitive. The default, CASE_SENSITIVE:NO, causes all module names to be converted to uppercase. CASE_SENSITIVE:YES causes current and subsequent key operations to behave as they do for object libraries. See Section 2.3 for a full description. This option is valid only for macro and text libraries. |
| GLOBALS:n | Specifies the maximum number of symbols the library can contain initially. By default, LIBRARY sets a maximum of 512 symbols for an object module library. (Macro, help, and text libraries do not have a symbol directory; therefore, the maximum for these libraries defaults to 0.) |
| HISTORY:n | Specifies the maximum number of library update history records that the library is to maintain. The maximum number of library update records you can specify is 32,767. The default is 20. |

| | |
|-----------|---|
| KEYSIZE:n | <p>Specifies the maximum name length of modules or symbols.</p> <p>On VAX systems, LIBRARY assigns default name lengths of 15 characters for help modules, 31 characters for modules in object or macro libraries, and 39 characters for modules in text or shareable image libraries. The maximum length you can specify for these names is 128 characters.</p> <p>Also on VAX systems, when you specify a key size value, remember that the MACRO compiler and the linker do not accept module names or symbol names in excess of 31 characters.</p> <p>On Alpha systems, LIBRARY assigns default name lengths of 15 characters for help modules, 31 characters for modules in macro libraries, 39 characters for modules in text libraries, and 128 characters for modules in object or shareable image symbol table libraries. The maximum length you can specify for these names is 128 characters.</p> <p>Also on Alpha systems, when you specify a key size value, remember that the MACRO compiler does not accept module names and symbol names in excess of 31 characters, and the linker does not accept module names in excess of 31 characters or global symbol names in excess of 64 characters.</p> <p>On I-64 systems, LIBRARY assigns default name lengths of 15 characters for help modules, 31 characters for modules in macro libraries, 39 characters for modules in text libraries, and 1024 characters for modules in object or shareable image symbol table libraries. The maximum length you can specify for these names is 1024 characters.</p> |
| MODULES:n | <p>Specifies the maximum number of modules the library can initially contain. By default, LIBRARY sets an initial maximum of 128 modules for all library types.</p> <p>A library's size can grow past its initial allocation. However, for optimum performance, it is best to allocate the maximum number of modules you expect to use.</p> |
| VERSION:n | <p>On VAX systems, specifies that the library is to be stored in OpenVMS Version 2.0 library format, if <i>n</i> is 2; or VMS Version 3.0 library format, if <i>n</i> is 3. On Alpha and I64 systems, this parameter is ignored.</p> |

If you specify more than one option, separate them with commas and enclose the list in parentheses.

Examples

1. `$ LIBRARY/CREATE TESTLIB ERRMSG,STARTUP`

This LIBRARY command creates an object module library named TESTLIB.OLB and places the files ERRMSG.OBJ and STARTUP.OBJ as modules in the library.

LIBRARIAN Qualifiers /CREATE

2. \$ LIBRARY/MACRO/CREATE=(BLOCKS:40,MODULES:100) MYMAC TEMP
\$ MACRO MYMAC/LIBRARY,CYGNUS/OBJECT

This LIBRARY command creates a macro library named MYMAC.MLB from the macros in the file TEMP.MAR. The new library has room for 100 modules in a 40-block file. If the input file contains multiple macros, each macro is entered in the new library.

/CROSS_REFERENCE

Requests a cross-reference listing of an object library.

Format

```
/CROSS_REFERENCE[=(option[,...])]
```

option

An option that produces a cross-reference listing that is not limited to only symbols by name and symbols by value. Options are listed in the Description section.

Description

If you omit this qualifier, cross-reference listings are not provided. If you specify /CROSS_REFERENCE without specifying an option, you get cross-reference listings that contain symbols by name and symbols by value. By default, the listing file is created in your current default directory and has the same file name as the library and a file type of .LIS. You can use the /OUTPUT qualifier to specify an alternate file specification for the listing file.

You can specify one or more of the following options:

| | |
|--------|--|
| ALL | All types of cross-references |
| MODULE | Cross-reference listing of both the symbol references in the module and the symbol definitions |
| NONE | No cross-reference listing |
| SYMBOL | Cross-reference listing by symbol name |
| VALUE | Cross-reference listing of symbols by value |

If you specify more than one option, separate the options with commas and enclose the list in parentheses.

Example

```
$ LIBRARY/CROSS_REFERENCE=ALL/OUTPUT=SYS$OUTPUT LIBRAR
```

This LIBRARY command requests a cross-reference listing of the object library LIBRAR.OLB. The cross-reference listing is displayed at the terminal. The listing includes cross-references by symbol, by value, and by module.

LIBRARIAN Qualifiers

/DATA

/DATA

Stores a library in data-reduced format or expands a library previously stored in data-reduced format.

Format

/DATA=option

option

The option REDUCE, which stores a library in data-reduced format, or the option EXPAND, which expands a library previously stored in data-reduced format. There is no default; you must specify one of the options.

Description

When you specify /DATA, the DCL command LIBRARY creates a new library. By default, the new library is created in your current default directory with the same file name as the existing library and a file type that is the default for the type of library created. You can use the /OUTPUT qualifier to specify an alternate file specification for the library.

You use the /DATA qualifier to control how data is stored in the library. If you specify /DATA=REDUCE, data in the library is stored in data-reduced format; less disk space is required for the library, but access to the library generally is slower.

Note

For I64 systems, HP strongly recommends that DCX data-reduced ELF object libraries first be expanded before performing Linker operations.

If you omit this qualifier, data is stored in the library in standard, rather than data-reduced, format. You can change a data-reduced library back to the standard format by specifying /DATA=EXPAND.

When you use the /DATA qualifier (with either option), LIBRARIAN also recovers space in the library that had been occupied by modules deleted from the library, just as if you had specified /COMPRESS.

Example

```
$ LIBRARY/TEXT/DATA=REDUCE TEXTLIB
```

This LIBRARY command stores the data in the text library TEXTLIB.TLB in data-reduced format.

/DELETE

Requests the LIBRARY command to delete (physically remove) one or more modules from a library.

Format

/DELETE=(module[,...])

module

The name of the module to be deleted.

Description

You must specify the names of the modules to be deleted. If you specify more than one module, separate the module names with commas and enclose the list in parentheses.

Wildcard characters are allowed in the module specification.

If you specify the /LOG qualifier with /DELETE, LIBRARY issues the following message:

```
%LIBRAR-S-DELETED, MODULE module-name DELETED FROM library-name
```

Example

```
$ LIBRARY/DELETE=FREEZE/LOG THAW
```

This LIBRARY command physically removes the module FREEZE from the object library THAW. A message is displayed to confirm that the module was deleted.

LIBRARIAN Qualifiers

/EXTRACT

/EXTRACT

Copies one or more modules from a library into a file.

Format

```
/EXTRACT=(module[,...])
```

module

The name of the module to be copied.

Description

If you specify more than one module, separate the module names with commas and enclose the list in parentheses.

Wildcard characters are allowed in the module specification.

If you specify the /OUTPUT qualifier with /EXTRACT, the LIBRARY command writes the output into the file specified by the /OUTPUT qualifier. If you do not specify a directory, the file is written to your current default directory. If you specify /EXTRACT and do not specify /OUTPUT, the LIBRARY command writes the file into a file that has the same file name as the library and a file type of .OBJ, .EXE, .MAR, .HLP, or .TXT, depending on the type of library.

Example

```
$ LIBRARY/EXTRACT=(ALLOCATE,APPEND)/OUTPUT=MYHELP SYS$HELP:HELPLIB.HLB
```

This LIBRARY command specifies that the modules ALLOCATE and APPEND are to be extracted from the help library HELPLIB.HLB and output to the file MYHELP.HLP in your current default directory.

/FULL

Requests a full description of each module in the module name table.

Format

/FULL

Description

Use the /FULL qualifier with the /LIST qualifier to request a list of each library module in the following format, where *Ident nn* is the identification number of the module:

module-name [Ident nn] Inserted dd-mmm-yyyy hh:mm:ss [n symbols]

The identification number and the number of symbols appear only in object libraries.

If an update history is maintained for the library, then /LIST/FULL/HISTORY lists the module name in the update history records.

Example

```
$ LIBRARY/LIST=MYMAC.LIS/FULL MYMAC.MLB
```

This LIBRARY command requests a full listing of the macro library MYMAC; the output is written to a file named MYMAC.LIS.

LIBRARIAN Qualifiers

/GLOBALS

/GLOBALS

For object and shareable image module libraries, controls whether the names of global symbols in modules being inserted in the library, as well as Unix-style weak symbols and group symbols from ELF objects, are included in the global symbol table.

Format

/GLOBALS

/NOGLOBALS

Description

By default, the `LIBRARY` command places the module's symbol names in the global symbol table. Use `/NOGLOBALS` if you do not want the symbol names included in the global symbol table.

Example

```
$ LIBRARY/INSERT/NOGLOBALS TOOLS SPELL
```

This `LIBRARY` command inserts the modules in `SPELL.OBJ` into the object library `TOOLS.OLB`, but symbol names in the inserted modules are not included in the library's global symbol table.

/HELP

Indicates that the library specified is a help library.

Format

/HELP

Description

When you use the /HELP qualifier, the library file type defaults to .HLB and the input file type defaults to .HLP.

Example

```
$ LIBRARY/HELP/CREATE ERRMSG EDITERRS
```

This LIBRARY command creates a help library called ERRMSG.HLB. Help text from the file EDITERRS.HLP is inserted into the library.

LIBRARIAN Qualifiers /HISTORY

/HISTORY

Requests that update history record headers be listed (for libraries that contain a history).

The operation referred to in the header has one of three values: replaced, inserted, or deleted.

Format

username operation n modules on dd-mmm-yyy hh:mm:ss

Description

The /HISTORY qualifier is used with the /LIST qualifier. Use the /HISTORY qualifier with /LIST/FULL to request that the names of updated modules be listed in addition to the update history headers.

Example

```
$ LIBRARY/LIST/HISTORY/MACRO SETUP
```

This LIBRARY command lists the headers of the update history records in the macro library SETUP.MLB.

/INSERT

Requests the LIBRARY command to add the contents of one or more files to an existing library.

Format

```
/INSERT
```

Description

If an object module input file consists of concatenated object modules, the LIBRARY command creates a separate entry for each object module in the file; each module name table entry reflects an individual module name. If a macro or help file specified as input contains more than one definition, the LIBRARY command creates a separate entry for each one, naming the module name table entries according to the names specified in the .MACRO directives or in the key-1 name in the help format (see Section 2.5.1).

Unlike object, macro, and help libraries, the input file in text libraries contains data records of undefined contents. Therefore, LIBRARIAN catalogs the entire input file as a single module using the file name (not the directory or file type) as the module name. If you want to rename the inserted module, use the /MODULE qualifier.

When you use the /INSERT qualifier to insert modules into an existing library, the Librarian utility checks the module name table before inserting each module. If a module name or symbol name already exists in the library, an error message is issued and the module or symbol is not added to the library.

For OpenVMS VAX libraries, the maximum record size (established by LBR\$C_MAXRECSIZ) that can be inserted into a library is 2048 bytes.

For OpenVMS Alpha and ELF libraries, the maximum record size (established by ELBR\$C_MAXRECSIZ) that can be inserted into a library is 8192 bytes.

To insert or replace a module in a library, regardless of whether a current entry exists with the same name, use the /REPLACE qualifier (the default operation).

Example

```
$ LIBRARY/INSERT TESTLIB SCANLINE  
$ LINK TERMTEST,TESTLIB/LIBRARY
```

This LIBRARY command adds the module SCANLINE.OBJ to the library TESTLIB.OLB. The library is specified as input to the linker by the /LIBRARY qualifier on the LINK command. If the module TERMTEST.OBJ refers to any routines or symbols not defined in TERMTEST, the linker searches the global symbol table of library TESTLIB.OLB to resolve the symbols.

LIBRARIAN Qualifiers

/LIST

/LIST

Controls whether the LIBRARY command creates a listing that provides information about the contents of the library.

Format

/LIST[=file-spec]

/NOLIST

file-spec

The file specification of the file to be listed.

Description

By default, LIBRARY does not produce a listing. If you specify /LIST without a file specification, LIBRARY writes the output file to the current SYS\$OUTPUT device. If you include a file specification that does not have a file type, LIBRARY uses the default file type .LIS.

If you specify /LIST with qualifiers that perform additional operations on the library, the LIBRARY command creates the listing after completing all other requests; thus, the listing reflects the status of the library after all changes have been made.

When you specify /LIST, the LIBRARY command provides, by default, the following information about the library:

```
Directory of OBJECT library  DBB0:[LIBRAR]LIBRAR.OLB;1 on 31-DEC-1993 10:08:28
Creation date: 12-DEC-1992 19:40:36      Creator: VAX-11 librarian V04-00
Revision date: 31-DEC-1992 16:04:58     Library format: 3.0
Number of modules:      15                Max. key length: 31
Other entries:          73                Preallocated index blocks: 35
Recoverable deleted blocks: 15           Total index blocks used: 12
Max. update history records: 10         Update history records: 5
```

Examples

1. \$ LIBRARY/LIST=MYMAC.LIS/FULL MYMAC.MLB

This LIBRARY command requests a full listing of the macro library MYMAC; the output is written to a file named MYMAC.LIS.

2. \$ LIBRARY/LIST/NAMES/ONLY=\$ONE/WIDTH=80 SYMBOLIB

This LIBRARY command requests a full listing of the module \$ONE, contained in the object library SYMBOLIB.OLB. The /WIDTH qualifier requests that the global symbol display be limited to 80 characters per line.

3. \$ LIBRARY/INSERT/LIST ALLOBJECTS *

This LIBRARY command inserts into ALLOBJECTS.OLB all object modules from all object files in the current directory. If any of the modules to be inserted have the same name as an existing module in the library, the existing module is replaced. The LIBRARY command then lists the resulting library on SYS\$OUTPUT.

/LOG

Controls whether the LIBRARY command verifies each library operation.

Format

/LOG

/NOLOG

Description

If you specify /LOG, the LIBRARY command displays the module name, followed by the library operation performed, followed by the library file specification.

Other applications of the /LOG qualifier appear in the descriptions of /DELETE and /REPLACE.

Example

```
$ LIBRARY/REMOVE=(LIB_EXTRCT_MODS,LIB_INPUT_MAC)/LOG LIBRAR
```

This LIBRARY command requests the removal of the global symbols LIB_EXTRCT_MODS and LIB_INPUT_MAC from the object library LIBRAR.OLB. The /LOG qualifier requests that the removal of the symbols be confirmed by messages.

LIBRARIAN Qualifiers

/MACRO

/MACRO

Indicates that the library specified is a macro library.

Format

/MACRO

Description

When you specify the /MACRO qualifier, the library file type defaults to .MLB and the input file type defaults to .MAR.

Example

```
$ LIBRARY/MACRO/INSERT MONTHS APRIL
```

This LIBRARY command inserts modules from APRIL.MAR into the macro library MONTHS.MLB.

/MODULE

Names a text module that you want to replace or insert into a text library. It also modifies the input file specification parameter.

Format

/MODULE=module-name

module-name

The name of the module to be inserted in the library.

Description

When you insert text modules into a library, the input file you specify is assumed to be a single module. Therefore, the file name of the input file specification becomes the module name. If you want the file you are inserting to have a module name different from its input file name, use the /MODULE qualifier to name the added module.

You can also use the /MODULE qualifier to enter a text module interactively. If you specify the logical name SYS\$INPUT as the input file and use the /MODULE qualifier, the LIBRARY command inserts the text you enter from the terminal into the specified library module. To terminate the terminal input, press Ctrl/Z.

Remember that the /MODULE qualifier is an input file qualifier; it assumes that you are either replacing or inserting a new text module. Therefore, the qualifiers that remove modules—/EXTRACT, /DELETE, /REMOVE—are incompatible with /MODULE.

Note that you must place the /MODULE qualifier after the input file you specify.

Example

```
$ LIBRARY/INSERT/TEXT TSTRING SYS$INPUT/MODULE=TEXT1
```

This LIBRARY command inserts a module named TEXT1 into the text library TSTRING.TLB. The input is taken from SYS\$INPUT.

LIBRARIAN Qualifiers /NAMES

/NAMES

When /LIST is specified for an object module library, controls whether the LIBRARY command lists the names of all symbols in the global symbol table as well as the module names in the module name table.

Format

/NAMES (Alpha and VAX)

/NAMES [= option] (I64 only)

/NONAMES (default)

option

The option keywords pertain to I64 systems only and can be one of the following keywords:

| Keyword | Explanation |
|----------|---|
| BYMODULE | Lists each module followed by a list of the symbols in the global symbol table that are associated with that module. This is the default listing format when no keyword is given with the /NAMES qualifier. |
| BYSYMBOL | Lists each symbol in the global symbol table followed by a list of modules with which the symbol is associated, in precedence order. |

Description

The /NAME qualifier lists the symbol names and the module names along with their association with each other. The default, /NONAMES, does not list the symbol names.

If you specify /NAME=BYSYMBOL, each symbol name is displayed followed by the modules with which the symbol is associated using the following format:

```
symbol "symbol name"  
  Global:  
    module-name  
    .  
    .  
    .  
  UxWk:  
    module-name  
    .  
    .  
    .  
  Group Global:  
    module-name  
    .  
    .  
    .  
  Group UxWk:  
    module-name  
    .  
    .  
    .  
symbol "symbol name"  
  UxWk:  
    module-name  
    .  
    .  
    .
```

Note

If you specify /NAMES and the library is a macro, help, or text library, no symbol names are displayed.

Example

```
$ LIBRARY/LIST/NAMES/ONLY=$ONE/WIDTH=80 SYMBOLIB
```

This LIBRARY command requests a full listing of the module \$ONE, contained in the object library SYMBOLIB.OLB. The /WIDTH qualifier requests that the global symbol display be limited to 80 characters per line.

LIBRARIAN Qualifiers

/OBJECT

/OBJECT

Indicates that the library specified is an object module library.

Format

/OBJECT

Description

Libraries are assumed to be object module libraries unless you specify the /SHARE, /MACRO, /TEXT, or /HELP qualifier. The library file type for object module libraries defaults to .OLB and the input file type defaults to .OBJ.

On OpenVMS VAX systems, the /OBJECT qualifier creates a VAX library by default. Note that you cannot have VAX modules and Alpha modules in the same library file. For more information, see the description of the /VAX (VAX and Alpha only) qualifier.

On OpenVMS Alpha systems, the /OBJECT qualifier creates an Alpha library by default. Note that you cannot have Alpha modules and VAX modules in the same library file. For more information, see the description of the /ALPHA qualifier.

On OpenVMS I64 systems, the /OBJECT qualifier creates only ELF object libraries.

Example

```
$ LIBRARY/OBJECT/INSERT MONTHS APRIL
```

This LIBRARY command inserts modules from APRIL.OBJ into the object library MONTHS.OLB. The /OBJECT qualifier is optional.

/ONLY

Specifies the individual modules on which the LIBRARY command can operate.

Format

/ONLY=(module-name[,...])

module-name

The module on which the LIBRARY command can operate.

Description

When you use the /ONLY qualifier, the LIBRARY command lists or cross-references only those modules specified.

If you specify more than one module, separate the module names with commas and enclose the list in parentheses.

The /ONLY qualifier must be used with the /LIST or /CROSS_REFERENCE qualifier.

Wildcard characters are allowed in the module name specification.

Example

```
$ LIBRARY/LIST/NAMES/ONLY=$ONE/WIDTH=80 SYMBOLIB
```

This LIBRARY command requests a full listing of the module \$ONE, contained in the object library SYMBOLIB.OLB. The /WIDTH qualifier requests that the symbol display be limited to 80 characters per line.

LIBRARIAN Qualifiers /OUTPUT

/OUTPUT

When used with the /EXTRACT, /COMPRESS, /CROSS_REFERENCE, or /DATA qualifier, specifies the file specification of the output file.

Format

/OUTPUT=file-spec

file-spec

The file specification of the output file.

Description

For /EXTRACT, the output file contains the modules extracted from a library; for /COMPRESS, the output file contains the compressed library; for /CROSS_REFERENCE, the output file contains the cross-reference listing; for /DATA, the output file contains the data-reduced or data-expanded library.

No wildcard characters are allowed in the file specification.

If you omit the file type in the file specification, a default is used depending on the library function qualifier and, in some cases, the library type qualifier, as follows:

| Qualifier | Library Type Qualifier | Default File Type |
|-----------------------|------------------------|-------------------|
| /COMPRESS or /DATA | /HELP | .HLB |
| | /MACRO | .MLB |
| | /OBJECT | .OLB |
| | /TEXT | .TLB |
| | /SHARE | .OLB |
| /CROSS_REFERENCE | — | .LIS |
| /EXTRACT | /HELP | .HLP |
| | /MACRO | .MAR |
| | /OBJECT | .OBJ |
| | /TEXT | .TXT |
| | /SHARE | .EXE |

Examples

1. `$ LIBRARY/EXTRACT=(ALLOCATE,APPEND)/OUTPUT=MYHELP SYS$HELP:HELPLIB.HLB`

This LIBRARY command specifies that the modules ALLOCATE and APPEND be extracted from the help library HELPLIB.HLB and output to the file MYHELP.HLP.

2. `$ LIBRARY/CROSS_REFERENCE=ALL/OUTPUT=SYS$OUTPUT LIBRAR`

This LIBRARY command requests a cross-reference listing of the object library LIBRAR.OLB. The cross-reference listing is displayed at the terminal. The listing includes cross-references by symbol, by value, and by module.

/REMOVE

Requests the LIBRARY command to delete one or more entries from the global symbol table in a library.

Alpha and VAX:

Format

%LIBRAR-S-INSERTED, MODULE module-name INSERTED IN library-file-spec

Example

```
$ LIBRARY/REPLACE/HELP HELPLIB NEWTEXT
```

This LIBRARY command inserts into the help library HELPLIB.HLB the help modules from the file NEWTEXT.HLP. If a help module in NEWTEXT.HLP has the same name as an existing help module in the library, the module from NEWTEXT.HLP replaces the existing module.

LIBRARIAN Qualifiers /SELECTIVE_SEARCH

/SELECTIVE_SEARCH

Defines the input modules being inserted into a library as candidates for selective searches by the linker.

Format

```
/SELECTIVE_SEARCH
```

Description

If you specify /SELECTIVE_SEARCH and the library is specified as a linker input file, the linker selectively searches the modules; the linker takes from the library, for the symbol table of its output image file, only those symbols that have been referenced by other modules.

Note that the selective search operation applies only to those modules that were inserted in the library by a LIBRARY command that included the /SELECTIVE_SEARCH qualifier; it does not apply to the library itself.

Example

```
$ LIBRARY/SELECTIVE_SEARCH/INSERT MATHLIB TRIG
```

This LIBRARY command inserts the modules in TRIG.OBJ into the library MATHLIB.OLB. The inserted modules are selectively searched when MATHLIB.OLB is specified as an input file to the linker.

/SHARE

Indicates that the library specified is a shareable image library.

Format

/SHARE

Description

This LIBRARY command assumes a file type of .OLB for the shareable image library and .EXE for the input files. See Section 2.4 for additional information.

On OpenVMS VAX systems, the /SHARE qualifier creates a VAX shareable image library by default. Note that you cannot have VAX modules and Alpha modules in the same library. For more information, see the description of the /VAX (VAX and Alpha only) qualifier.

On OpenVMS Alpha systems, the /SHARE qualifier creates an Alpha shareable image library by default. Note that you cannot have Alpha modules and VAX modules in the same library. For more information, see the description of the /ALPHA qualifier.

On OpenVMS I64 systems, the /SHARE qualifier creates only ELF sharable image libraries.

SYS\$LIBRARY:IMAGELIB.OLB is an example of a sharable image library.

Example

```
$ LIBRARY/SHARE/CREATE SHARELIB.OLB
```

This LIBRARY command creates a shareable image library called SHARELIB.OLB.

LIBRARIAN Qualifiers

/SINCE

/SINCE

Specifies that only those modules inserted later than a particular time be listed.

Format

```
/SINCE [=time] 00
```

time

Limits the modules to be listed to those inserted in the library since a specified time.

You can specify an absolute time or a combination of absolute and delta times. For details about specifying times, see the *HP OpenVMS DCL Dictionary*.

Description

This qualifier is used with the /LIST qualifier. If you omit the /SINCE qualifier, you obtain all the modules regardless of the date. If you specify /SINCE without a date or time, the default is to provide the modules inserted since today.

Example

```
$ LIBRARY/HELP/LIST/SINCE=:12 ERRMSG
```

This LIBRARY command displays information about help modules added to ERRMSG.HLB since noon today.

/SQUEEZE

Controls whether the LIBRARY command compresses individual macros before adding them to a macro library.

Format

```
/SQUEEZE  )  
/NOSQUEEZE  )
```

Description

When you specify /SQUEEZE, which is the default, trailing blanks, trailing tabs, and comments are deleted from each macro before its insertion in the library.

Use /SQUEEZE only with the /CREATE, /INSERT, and /REPLACE qualifiers to conserve space in a macro library. If you want to retain the full macro, specify /NOSQUEEZE.

Example

```
$ LIBRARY/MACRO/NOSQUEEZE/INSERT MYMACS MYMACS
```

This LIBRARY command inserts the macros in MYMACS.MAR into the library MYMACS.MLB. Trailing blanks, trailing tabs, and comments are not deleted from each macro before its insertion into the library.

LIBRARIAN Qualifiers

/TEXT

/TEXT

Indicates that the library specified is a text library.

Format

/TEXT

Description

When you use the /TEXT qualifier, the library file type defaults to .TLB and the input file type defaults to .TXT.

Examples

1. `$ LIBRARY/INSERT/TEXT TSTRING SYS$INPUT/MODULE=TEXT1`

This LIBRARY command inserts a module named TEXT1 into the text library TSTRING.TLB. The input is taken from SYS\$INPUT.

2. `$ LIBRARY/INSERT/TEXT TSTRING TEXT2`

This LIBRARY command inserts the contents of the file TEXT2.TXT into the text library TSTRING.TLB. The name of the inserted module is TEXT2.

/VAX (VAX and Alpha only)

Directs LIBRARIAN to work with an OpenVMS VAX object library when used with the /OBJECT qualifier or to work with an OpenVMS VAX shareable image library when used with the /SHARE qualifier. When used with the /CREATE qualifier, LIBRARIAN creates an OpenVMS VAX library of either an object or shareable image type depending whether /OBJECT or /SHARE is specified.

The default is /ALPHA on OpenVMS Alpha systems and /VAX on OpenVMS VAX systems. The OpenVMS I64 Librarian does not accept this qualifier because the I64 Librarian works exclusively with I64 libraries.

Format

/VAX

Description

On OpenVMS Alpha systems, use the /VAX qualifier to create and manipulate OpenVMS VAX object and shareable image libraries. Because the formats of macro, help, and text libraries on OpenVMS Alpha systems are identical to those on OpenVMS VAX systems, using the /VAX qualifier with the /MACRO, /HELP, and /TEXT qualifiers has no effect.

Note

You cannot have both OpenVMS Alpha and OpenVMS VAX object modules in one object library, nor can you have OpenVMS Alpha and OpenVMS VAX shareable images in the same shareable image library.

Examples

1. \$ LIBRARY/VAX/CREATE TESTLIB ERRMSG.OBJ,STARTUP.OBJ

This LIBRARY command creates a VAX object module library named TESTLIB.OLB and places the files ERRMSG.OBJ and STARTUP.OBJ as modules in the library.

2. \$ LIBRARY/VAX/SHARE/CREATE SHARLIB

This LIBRARY command creates a VAX shareable image library called SHARLIB.OLB.

LIBRARIAN Qualifiers

/WIDTH

/WIDTH

Controls the screen display width (in characters) for listing global symbol names.

Format

/WIDTH =

n

The width of the screen display.

Description

Specify the /WIDTH qualifier with the /NAMES qualifier to limit the line length of the /NAMES display.

The default display width is the width of the listing device. The maximum width is 132.

Example

```
$ LIBRARY/LIST/NAMES/ONLY=$ONE/WIDTH=80 SYMBOLIB
```

This LIBRARY command requests a full listing of the module \$ONE, contained in the object library SYMBOLIB.OLB. The /WIDTH qualifier requests that the global symbol display be limited to 80 characters per line.

MESSAGE Description

The Message utility (MESSAGE) lets you supplement OpenVMS system messages with your own messages. Your messages can indicate that an error has occurred, or they can indicate other conditions; for example, that a routine has run successfully or that a default value has been assigned.

This section describes how to use the Message utility.

3.1 Message Format

Messages are displayed as a line of alphanumeric codes. The text of the message explains the condition that caused the message to be displayed. Messages are displayed in the following format:

```
%FACILITY-L-IDENT, message-text
```

FACILITY

Specifies the abbreviated name of the software component that issued the message.

L

Shows the severity level of the condition that caused the message. The five severity levels are represented by the following codes:

| | |
|---|-----------------|
| S | Success |
| I | Informational |
| W | Warning |
| E | Error |
| F | Fatal or severe |

IDENT

Identifies a symbol of up to 15 characters that represents the message.

message-text

Explains the cause of the message. The message text can include up to 255 formatted-ASCII-output (FAO) arguments. For example, an FAO argument can be used to display the instruction where an error occurred or a value that you should be aware of.

% and ,

Included as delimiters if any of the first three fields—FACILITY, L, or IDENT—are present.

If you suppress FACILITY, L, and IDENT, the first character of the message text is capitalized by the Put Message (\$PUTMSG) system service. The following example is a typical message:

```
%TYPE ①-W- ②OPENIN ③, error opening _DBO:[ROSE]STATS.FOR;④ as input ⑤
```

- ① TYPE is the facility.
- ② W (Warning) is the severity level.
- ③ OPENIN is the IDENT.
- ④ _DBO:[ROSE]STATS.FOR is the FAO argument.

MESSAGE Description

- ⑤ “Error opening _DBO:[ROSE]STATS.FOR; as input” is the message text.

3.2 Constructing Messages

You construct messages by writing a message source file, compiling it using the Message utility, and linking the resulting object module with your facility object module. When you run your program, the Put Message (\$PUTMSG) system service finds the information to use in the message by using a message argument vector.

The message argument vector includes the message code, a 32-bit value that uniquely identifies the message. The message code, which is created from information defined in the message source file, consists of the following:

- The severity level defined in the severity directive or message definition
- The message number assigned automatically by a message definition or specified with the base message number directive
- The facility number defined in the facility directive
- Internal control flags

Figure 3–1 shows the arrangement of the bits in the message code.

Figure 3–1 Message Code

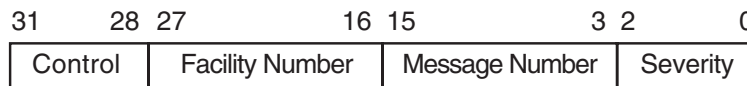

ZK-0866-GE

You can refer to the message code in your programs by means of a global symbol called the message symbol, which also is defined by information from the message source file. The message symbol, which appears in the compiled message file, consists of the following:

- The symbol prefix defined in the facility directive
- The symbol name defined in the message definition

3.2.1 The Message Source File

The message source file consists of message definition statements and directives that define the message text, the message code values, and the message symbol. The various elements that can be included in a message source file are as follows:

- Facility directive
- Severity directive
- Base message number directive
- Message definition
- Literal directive
- Identification directive
- Listing directives

- End directive

Usually, the first statement in a message source file is a `.TITLE` directive, which lets you specify a module name for the compiled message file. You must specify a `.FACILITY` directive after the `.TITLE` directive. All the messages defined after a `.FACILITY` directive are associated with that facility. A `.END` directive or a new `.FACILITY` directive ends the list of messages associated with a particular facility.

You must define a severity level for each message either by specifying a `.SEVERITY` directive or by including a severity qualifier as part of the message definition.

Each message defined in the message source file must have a facility and a message definition associated with it. All other message source file statements are optional. See the MESSAGE Commands section for a detailed description of the format of each of these message source file statements.

The `TESTMSG.MSG` file that follows is a sample message source file. The messages for the associated FORTRAN program, `TEST.FOR`, are defined in `TESTMSG.MSG` with the following lines:

```
.FACILITY      TEST,1 /PREFIX=MSG_  
.SEVERITY      ERROR  
SYNTAX         <Syntax error in string '!AS'>/FAO=1  
ERRORS         <Errors encountered during processing>  
.END
```

The FORTRAN program, `TEST.FOR`, contains the following lines:

```
EXTERNAL MSG SYNTAX,MSG ERRORS  
CALL LIB$SIGNAL(MSG_SYNTAX,%VAL(1),'ABC')  
CALL LIB$SIGNAL(MSG_ERRORS)  
END
```

In addition to defining the message data, `TESTMSG.MSG` also defines the message symbols `MSG_SYNTAX` and `MSG_ERRORS` that are included as arguments in the procedure calls of `TEST.FOR`. The function `%VAL` is a required FORTRAN compile-time function. The first call also includes the string `ABC` as an `FAO` argument.

3.2.2 Compiling the Message Source File

You must compile message source files into object modules before you can use the messages defined in them. You compile your message source file by entering the `MESSAGE` command followed by the file specification of the message source file. For example:

```
$ MESSAGE TESTMSG
```

This command compiles the message source file `TESTMSG.MSG` and creates an object module file `TESTMSG.OBJ`.

For your convenience, you can put message object modules into object module libraries, which you can then link with facility object modules.

MESSAGE Description

3.2.3 Linking the Message Object Module

After you compile the message file, you must link the message object module with the facility object module (created when the source file was compiled) to produce one executable image file.

For example, use the following command to link the message object module TESTMSG.OBJ to the FORTRAN object module TEST.OBJ to create the executable program TEST.EXE:

```
$ LINK/NOTRACE TEST+TESTMSG
```

At this point, you can execute the program, which contains both the message data and the facility code, with the following command:

```
$ RUN TEST
```

If an error occurs when you execute the program, the following messages are displayed:

```
%TEST-E-SYNTAX, Syntax error in string ABC  
%TEST-E-ERRORS, Errors encountered during processing
```

3.3 Using Message Pointers

Message pointers are generally used when you need to provide different message texts for the same set of messages; for example, a multilingual situation. When you use message pointers, you do not link the message object module directly with the facility object module. Consequently, you do not have to relink the executable image file to change the message text included in it.

To use a pointer, you must create a nonexecutable message file that contains the message text and a pointer file that contains the symbols and pointer to the nonexecutable file.

You create the nonexecutable message file by compiling and linking a message source file. For example, to create the nonexecutable message file COBOLMF.EXE, you first create the object module by compiling the message source file, COBOLMSG.MSG, with the following command:

```
$ MESSAGE/NOSYMBOLS COBOLMSG
```

You link the resulting object module with the following command:

```
$ LINK/SHAREABLE=SYS$MESSAGE:COBOLMF COBOLMSG.OBJ
```

By default, the linker places newly created images in your default device and directory. In the preceding example, the nonexecutable image COBOLMF.EXE is placed in the system message library SYS\$MESSAGE.

You create the pointer file by recompiling the message source file with the MESSAGE/FILE_NAME command. To avoid confusion, the pointer file should have a different file name from the nonexecutable file.

The object module resulting from the MESSAGE/FILE_NAME command contains only global symbols and the file specification of the nonexecutable message file.

For example, the following command creates the object module MESPNTN.OBJ, which contains a pointer to the nonexecutable message file COBOLMF.EXE:

```
$ MESSAGE/FILE_NAME=COBOLMF /OBJECT=MESPNTN COBOLMSG
```

MESSAGE Description

In addition to the pointers, the object module MESPNTN.OBJ contains the global symbols defined in the message source file COBOLMSG.MSG. If the destination of the nonexecutable message file is not SYS\$MESSAGE, you must specify the device and directory in the file specification for the /FILE_NAME qualifier.

After you create the pointer object module, you can then link it with the facility object module.

For example, the following command links the object module MESPNTN.OBJ to the COBOL program COBOLCODE:

```
$ LINK COBOLCODE,MESPNTN
```

When you run the resulting facility image file, the Get Message (\$GETMSG) system service retrieves the message data from the message file COBOLMF.

Figure 3-2 illustrates the relationship of the files in this example.

Figure 3-2 Creating a Message Pointer

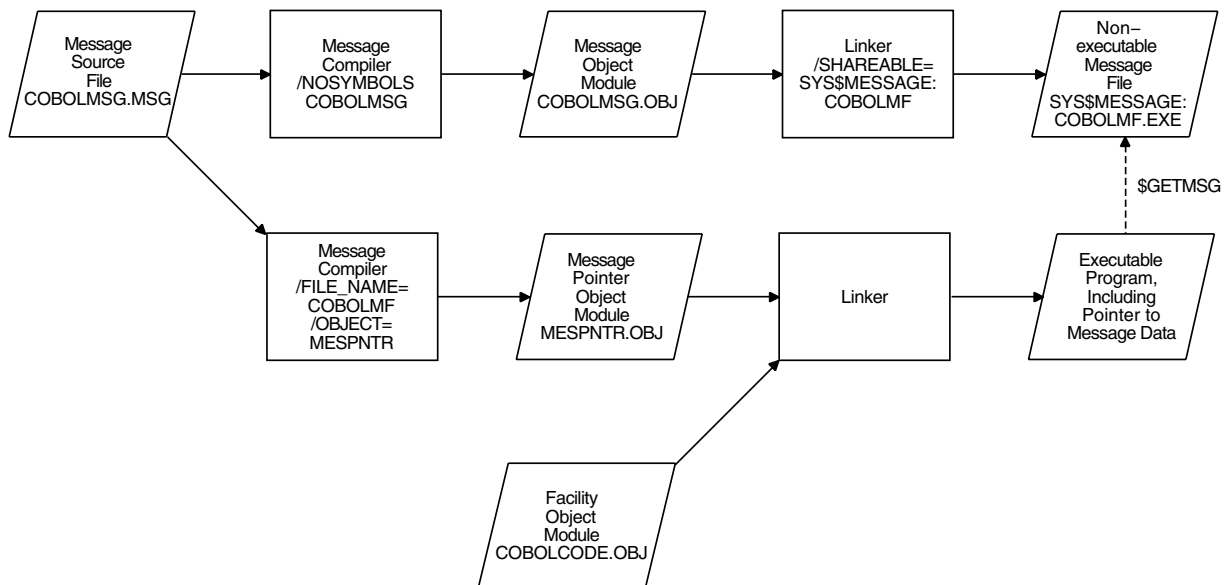

ZK-0868-GE

On Alpha systems, by default, the message compiler creates OpenVMS Alpha object modules from message source files. The /VAX qualifier causes the compiler to produce OpenVMS VAX object modules from those same message source files.

Note that you must convert messages to OpenVMS VAX object format if you want to link them against other OpenVMS VAX objects. For more information, see the *HP OpenVMS Linker Utility Manual*.

MESSAGE Description

3.4 The SET MESSAGE Command

The SET MESSAGE command allows you to do the following:

- Suppress or enable the various fields of the messages in your process
- Supplement the system message data with the message data in a nonexecutable message image for your process

For example, the following SET MESSAGE command specifies that the message information in MYMSG.EXE supplements the existing system messages:

```
$ SET MESSAGE MYMSG
```

In addition, the SET MESSAGE command used with one or more qualifiers suppresses or enables one or more fields in a message. For example, the following command suppresses the IDENT field in a message:

```
$ SET MESSAGE/NOIDENTIFICATION
```

For more information about the SET MESSAGE command, see the *HP OpenVMS DCL Dictionary*.

3.5 Message Source Files

The message source file contains statements or directives and the information included in the message, the message code, and the message symbol.

Source File Statements

Message source file statements are embedded within a message source file. Generally, message source file statements help construct the message code and the message symbol and control output listings. The message source file statements are as follows:

- Facility directive (.FACILITY)
- Severity directive (.SEVERITY)
- Base message number directive (.BASE)
- Message definition message-name
- End directive (.END)
- Literal directive (.LITERAL)
- Identification directive (.IDENT)
- Listing directives
 - Title directive (.TITLE)
 - Page directive (.PAGE)

Many of these statements accept qualifiers and parameters. The specific format of each of the message source file statements is described in detail in the MESSAGE Commands section.

Any line in the message source file, except lines that contain the .TITLE directive, can include a comment delimited by an exclamation point. You can insert extra spaces and tabs in any line to improve readability.

The listing title specified with the `.TITLE` directive and the message text specified in the message definition must occupy only one line. All other statements in a message source file can occupy any number of lines; text that continues onto the next line must end with a hyphen.

Defining Symbols in the Message Source File

Symbols defined in the message source file can include any of the following characters:

- Uppercase and lowercase letters (A,a,B,b . . . Z,z)
- Digits (1,2,3 . . . 9)
- Dollar sign (\$)
- Underscore (_)

Using Expressions in the Message Source File

Expressions used in the message source file can include any of the following radix operators:

`^X` Hexadecimal
`^O` Octal
`^D` Decimal

Radix operators specify the radix of a numeric value. The default radix is decimal.

Expressions can include symbols and the plus sign (+), which assigns a positive value, and minus sign (–), which assigns a negative value. Expressions can include the following binary operators:

+ Addition
– Subtraction
* Multiplication
/ Division
@ Arithmetic shift

Expressions can also include parentheses as grouping operators. Expressions enclosed in parentheses are evaluated first; nested parenthetical expressions are evaluated from inside to outside.

MESSAGE Usage Summary

The Message utility (MESSAGE) lets you supplement system messages with your own messages. Your messages can indicate that an error has occurred, or they can indicate other conditions; for example, that a routine has run successfully or that a default value has been assigned.

Format

```
MESSAGE file-spec[,...]
```

Command Parameter

file-spec

Specifies the message source file to be compiled. If you do not specify a file type, the default is .MSG. Wildcard characters are allowed in file specifications.

If you specify more than one message source file, separated by either commas or plus signs, the files are concatenated and compiled as a single file.

If you specify SYS\$INPUT, the message source files must immediately follow the MESSAGE command in the input stream, and both the object module name, identified by the /OBJECT qualifier, and the listing file name, identified by the /LIST qualifier, must be stated explicitly.

Usage Summary

The DCL command MESSAGE invokes the Message utility. After compiling the message source file, the Message utility returns you to DCL command level. For details about message statements and directives, qualifiers, and parameters in message source files, see the MESSAGE Commands section.

MESSAGE Qualifiers

MESSAGE command qualifiers let you specify the type and contents of output files produced. In addition, MESSAGE command qualifiers let you create nonexecutable message files that contain pointers to files that contain message data. Output files produced by command qualifiers are named according to the rules described in the *HP OpenVMS DCL Dictionary*.

MESSAGE Qualifiers

/ALPHA

/ALPHA

Directs MESSAGE to create an OpenVMS Alpha message object file. The default is to create OpenVMS Alpha message object files on OpenVMS Alpha systems and to create OpenVMS VAX message object files on OpenVMS VAX systems.

Format

/ALPHA

Description

Directs the message compiler to create an OpenVMS Alpha object modules from message source files.

Note that you must compile message source files using /ALPHA (default on OpenVMS Alpha systems) to link with other OpenVMS Alpha object modules and that you must compile using /VAX to link with OpenVMS VAX object modules. For more information, see the *HP OpenVMS Linker Utility Manual*.

Example

```
$ MESSAGE/ALPHA TESTMSG
```

This MESSAGE command creates an OpenVMS Alpha message object module named TESTMSG.OBJ by compiling the message source file TESTMSG.MSG.

/FILE_NAME

Specifies whether the object module contains a pointer to a file containing message data.

Format

/FILE_NAME=file-spec

/NOFILE_NAME

file-spec

Identifies a nonexecutable message file. The default device and directory for the file specification is SYS\$MESSAGE and the default file type is .EXE. No wildcard characters are allowed in the file specification.

Description

The /[NO]FILE_NAME qualifier specifies whether the object module contains a pointer to a file containing message data. By default, the object module contains only compiled message information and no pointers.

The /FILE_NAME and /TEXT qualifiers cannot be used together because a message pointer file cannot contain message text. The message text is contained in the nonexecutable message file, specified by the /FILE_NAME qualifier.

Examples

1. \$ MESSAGE COBOLMSG

This MESSAGE command creates the message object module COBOLMSG.OBJ by compiling the message source file COBOLMSG.MSG. The default qualifier /NOFILE_NAME is implied.

2. \$ MESSAGE/FILE_NAME=COBOLMF COBOLMSG

This MESSAGE command creates a message pointer file COBOLMSG.OBJ, which contains a pointer to the nonexecutable message file SYS\$MESSAGE:COBOLMF.EXE.

MESSAGE Qualifiers

/LIST

/LIST

Controls whether an output listing is created and, optionally, provides an output file specification for the listing.

Format

/LIST[=file-spec]

/NOLIST

file-spec

Specifies an output file specification for the listing file. The default device and directory are the current device and directory. The default file type is .LIS. No wildcard characters are allowed in the file specification.

Description

The /LIST qualifier creates a listing file. If you do not specify a file specification, the listing file has the same name as the first message source file being compiled and a file type of .LIS. When you compile message source files in batch mode, the output listing is created by default; however, in interactive mode, the default is to produce no output listing.

Example

```
$ MESSAGE/LIST=MSGOUTPUT COBOLMSG
```

This MESSAGE command compiles the message source file COBOLMSG.MSG and creates the output listing MSGOUTPUT.LIS in your current directory.

/OBJECT

Controls whether an object module is created by the message compiler and, optionally, provides a file specification for the object module.

Format

/OBJECT[=file-spec]

/NOOBJECT

file-spec

Specifies a file specification for the object module. The default device and directory are the current device and directory. No wildcard characters are allowed in the file specification.

Description

By default, the message compiler creates an object module that contains the message data. If you do not specify a file specification, the object module has the same name as the first message source file being compiled and a file type of .OBJ.

Examples

1. \$ MESSAGE COBOLMSG

This MESSAGE command creates the message object module COBOLMSG.OBJ by compiling the message source file COBOLMSG.MSG. The default qualifier /OBJECT is implied.

2. \$ MESSAGE/FILE_NAME=COBOLMF /OBJECT=MESPNTNTR COBOLMSG

This MESSAGE command creates the object module MESPNTNTR.OBJ, which contains a pointer to the nonexecutable message file COBOLMF.EXE.

MESSAGE Qualifiers

/SYMBOLS

/SYMBOLS

Controls whether global symbols are present in the object module. By default, object modules are created with global symbols.

Format

/SYMBOLS

/NOSYMBOLS

Description

By default, the message compiler creates an object module with global symbols. The /SYMBOLS qualifier requires that the /OBJECT qualifier be in effect, either explicitly or implicitly. If you are creating both a pointer object module and a nonexecutable message image, you can compile the object module, which becomes the nonexecutable image, with the /NOSYMBOLS qualifier. The symbols have to be in the pointer object module only.

Example

```
$ MESSAGE/FILE_NAME=COBOLMF /OBJECT=MESPNTTR/SYMBOLS COBOLMSG
```

This MESSAGE command creates the object module MESPNTTR.OBJ, which contains global symbols.

/TEXT

Controls whether the message text is present in the object module.

Format

/TEXT
/NOTEXT

Description

By default, the message compiler creates an object module that contains message text. The message text is obtained from the nonexecutable message file specified by the /FILE_NAME qualifier. The /TEXT and /FILE_NAME qualifiers cannot be used together because a message pointer file cannot contain message text.

The /TEXT qualifier requires that the /OBJECT qualifier be in effect, either explicitly or implicitly.

You can use the /NOTEXT qualifier with the /SYMBOLS qualifier to produce an object module containing only global symbols.

Example

```
$ MESSAGE/FILE_NAME=COBOLMF/NOTEXT /OBJECT=MESPNTN COBOLMSG
```

This MESSAGE command creates the object module MESPNTN.OBJ, which does not contain text; instead, it contains a pointer to the nonexecutable message file COBOLMF.EXE.

MESSAGE Qualifiers

/VAX

/VAX

Directs MESSAGE to create an OpenVMS VAX message object file. The default is to create OpenVMS Alpha message object files on OpenVMS Alpha systems and to create OpenVMS VAX message object files on OpenVMS VAX systems.

Format

/VAX

Description

Directs the message compiler to create an OpenVMS VAX object modules from message source files.

Note that you must compile message source files using /ALPHA to link with other OpenVMS Alpha object modules and that you must compile using /VAX (default on OpenVMS VAX systems) to link with OpenVMS VAX object modules. For more information, see the *HP OpenVMS Linker Utility Manual*.

Example

```
$ MESSAGE/VAX TESTMSG
```

This MESSAGE command creates an OpenVMS VAX message object module named TESTMSG.OBJ by compiling the message source file TESTMSG.MSG.

MESSAGE Commands

This section describes the message source file statements.

MESSAGE Commands

Base Message Number Directive

Base Message Number Directive

Defines the value used in constructing the message code.

Format

```
.BASE number
```

Parameter

number

Specifies a message number to be associated with the next message definition or an expression that is evaluated as the desired number.

Qualifiers

None.

Description

By default, all of the messages following a facility directive are numbered sequentially, beginning with 1.

If you need to supersede this default numbering system (for example, if you want to reserve some message numbers for future assignment), specify a message number of your choice using the base message number directive. The message number is used as a base for the sequential numbering of all messages that follow until either another .BASE directive or the end of the messages belonging to the facility is encountered. Note that the maximum number for any message cannot exceed 4095.

Example

```
.TITLE          SAMPLE Error and Warning Messages
.IDENT          'VERSION 4.00'
.FACILITY       SAMPLE,1/PREFIX=ABC_ ❶
.SEVERITY       ERROR

UNRECOG        < Unrecognized keyword !AS>/FAO_COUNT=1
AMBIG          < Ambiguous keyword>

.SEVERITY       WARNING
.BASE          10 ❷
SYNTAX         < Invalid syntax in keyword>

.END
```

❶ The facility number (facnum) in the facility statement defines the first two message numbers as 1 and 2.

❷ The base message number directive supersedes this sequential numbering by assigning the message number 10 to the third message.

End Directive

Terminates the entire list of messages for the facility.

Format

.END

Parameters

None.

Qualifiers

None.

Description

The .END directive terminates the entire list of messages for a facility. A .FACILITY directive also terminates a list of messages.

Example

```
.TITLE          SAMPLE Error and Warning Messages
.IDENT          'VERSION 4.00'
.FACILITY       SAMPLE,1/PREFIX=ABC_
.SEVERITY      ERROR

UNRECOG        < Unrecognized keyword !AS>/FAO_COUNT=1
AMBIG          < Ambiguous keyword>

.SEVERITY      WARNING
.BASE          10
SYNTAX         < Invalid syntax in keyword>
.END ❶
```

❶ The .END directive terminates the list of messages for the SAMPLE facility.

MESSAGE Commands

Facility Directive

Facility Directive

Specifies the facility to which the messages apply.

Format

```
.FACILITY [/qualifier,...] facnam[,]facnum [/qualifier,...]
```

Parameters

facnam

Specifies the facility name used in the facility field of the message and in the symbol representing the facility number. The facility name can be up to 9 characters.

facnum

Specifies the facility number used to construct the 32-bit value of the message code. A decimal value in the range 1 to 2047, or an expression that evaluates to a value in that range, can be used. The system manager usually assigns facility numbers so that no two facilities have the same number.

Qualifiers

/PREFIX=prefix

Defines an alternate symbol prefix to be used in the message symbol for all messages referring to this facility. The default symbol prefix is the facility name followed by an underscore (_). If the /SYSTEM qualifier is also specified, the default prefix is the facility name followed by a dollar sign and an underscore (\$_). The combined length of the prefix and the message symbol name cannot exceed 31 characters. The maximum length of an alternate symbol prefix created with the /PREFIX qualifier is 9 characters.

/SHARED

Inhibits the setting of the facility-specific bit in the message code. The /SHARED qualifier is used only for system services and shared messages and is reserved for use by Compaq.

/SYSTEM

Inhibits the setting of the customer facility bit in the message code. This qualifier is reserved for use by Compaq.

Description

The .FACILITY directive is the first directive in a message source file. All of the lines following a .FACILITY directive apply to that facility until a .END directive or another facility statement is reached. You must specify the facility name and the facility number in a .FACILITY directive. The facility name and facility number are separated by a comma or by any number of spaces or tabs.

The .FACILITY directive creates a global symbol of the following form:

```
facnam$_FACILITY
```

You can use this symbol to refer to the facility number assigned to the facility.

Example

```
.TITLE          SAMPLE Error and Warning Messages
.IDENT          'VERSION 4.00'
.FACILITY       SAMPLE,1/PREFIX=ABC_ ❶
.SEVERITY      ERROR

UNRECOG        < Unrecognized keyword !AS>/FAO_COUNT=1
AMBIG          < Ambiguous keyword>

.SEVERITY      WARNING
.BASE          10
SYNTAX         < Invalid syntax in keyword>

.END
```

❶ The facility statement in this message source file defines the messages belonging to the facility (facnam) **SAMPLE** with a facility number (facnum) of 1. The message numbers begin with 1 and continue sequentially. The `/PREFIX=ABC_` qualifier defines the message symbols `ABC_UNRECOG`, `ABC_AMBIG`, and `ABC_SYNTAX`.

MESSAGE Commands

Identification Directive

Identification Directive

Identifies the object module the Message utility produces.

Format

```
.IDENT string
```

Parameter

string

Identifies the object module; for example, a string that identifies a version number. If it is not delimited, the string is a 1- to 31-character string of alphanumeric characters, underscores, and dollar signs. If other characters are used, the string must be delimited with either apostrophes or quotation marks.

Qualifiers

None.

Description

The .IDENT directive is used in addition to the name you assign to the module with the .TITLE directive. You can label the object module by specifying a character string with the directive. If a message source file contains more than one identification directive, the last directive establishes the character string that forms part of the object module identification.

Example

```
.TITLE          SAMPLE Error and Warning Messages
.IDENT          'VERSION 4.00' ❶
.FACILITY       SAMPLE,1/PREFIX=ABC_
.SEVERITY       ERROR

UNRECOG        <Unrecognized keyword !AS>/FAO_COUNT=1
AMBIG          <Ambiguous keyword>

.SEVERITY       WARNING
.BASE          10
SYNTAX         < Invalid syntax in keyword>

.END
```

❶ This IDENT directive identifies the object module that the Message utility produces.

Literal Directive

Defines global symbols in your message source file. You can either assign values to these symbols or use the default values the directive provides.

Format

```
.LITERAL symbol[=value][,...]
```

Parameters

symbol

Specifies a symbol name.

value

Specifies any valid expression. If you omit the value, a default value is assigned. The default value is 1 for the first symbol in the directive and 1 plus the last value assigned for subsequent symbols.

Qualifiers

None.

Description

You can use the `.LITERAL` directive to define a symbol as the value of another previously defined symbol, or as an expression that results from operations performed on previously defined symbols.

Examples

```
1. .LITERAL A,B,C
```

The values of A, B, and C will be 1, 2, and 3.

```
2. .FACILITY SAMPLE,1/PREFIX=MSG$_  
.SEVERITY ERROR  
FIRST < first error>
```

```
.  
.  
.
```

```
LAST < last error>
```

```
.LITERAL LASTMSG=MSG$_LAST ❶
```

```
.LITERAL NUMSG=(MSG$_LAST@-3)-(MSG$_FIRST@-3) !number of messages ❷
```

In this example, symbols defined in the facility and message definition statements are used to assign values to symbols created with the `.LITERAL` directives.

❶ The first `.LITERAL` directive defines a symbol that has the value of the last 32-bit message code defined.

❷ The second `.LITERAL` directive defines the total number of messages in the source file.

MESSAGE Commands

Message Definition

Message Definition

Defines the message symbol, the message text, and the number of FAO arguments that can be printed with the message.

Format

```
name[/qualifier,...] <message-text>[/qualifier,...]
```

Parameters

name

Specifies the name that is combined with the symbol prefix (defined in the .FACILITY directive) to form the message symbol. The combined length of the prefix and the message symbol name cannot exceed 31 characters.

The name is used in the IDENT field of the message unless you specify the /IDENTIFICATION qualifier in the message definition.

message-text

Defines the text explaining the condition that caused the message to be displayed. The message text can be delimited either by angle brackets or by quotation marks. The text can be up to 255 bytes long; however, you cannot continue the delimited text onto another line. The message text can include FAO directives that insert ASCII strings into the resulting message; the Formatted ASCII Output (\$FAO) system service uses these directives. If you include an FAO directive, you must also use the /FAO_COUNT qualifier.

Qualifiers

/FAO_COUNT=*n*

Specifies the number of FAO arguments to be included in the message at execution time. The number specified must be a decimal number in the range 0 to 255. The Put Message (\$PUTMSG) system service, when constructing the final message text, uses *n* to determine how many arguments are to be given to the \$FAO system service. The default value for *n* is 0.

/IDENTIFICATION=*name*

Specifies an alternate character string to be used as the IDENT field of the message. The name can include up to nine characters. If you do not specify this qualifier, the name defined in the message definition is used.

/USER_VALUE=*n*

Specifies an optional user value that can be associated with the message. The value must be a decimal number in the range of 0 to 255. The default is 0. The value can be retrieved by the Get Message (\$GETMSG) system service for use in classifying messages by type or by action to be taken.

/SUCCESS

Specifies the level SUCCESS for a message. This qualifier overrides any .SEVERITY directive in effect. If no .SEVERITY directive is in effect, you must use this qualifier to specify the SUCCESS level.

/INFORMATIONAL

Specifies the level INFORMATIONAL for a message. This qualifier overrides any .SEVERITY directive in effect. If no .SEVERITY directive is in effect, you must use this qualifier to specify the INFORMATIONAL level.

/WARNING

Specifies the level WARNING for a message. This qualifier overrides any .SEVERITY directive in effect. If no .SEVERITY directive is in effect, you must use this qualifier to specify the WARNING level.

/ERROR

Specifies the level ERROR for a message. This qualifier overrides any .SEVERITY directive in effect. If no .SEVERITY directive is in effect, you must use this qualifier to specify the ERROR level.

/SEVERE

Specifies the level SEVERE for a message. This qualifier overrides any .SEVERITY directive in effect. If no .SEVERITY directive is in effect, you must use this qualifier to specify the SEVERE level.

/FATAL

Specifies the level FATAL for a message. This qualifier overrides any .SEVERITY directive in effect. If no .SEVERITY directive is in effect, you must use this qualifier to specify the FATAL level.

Description

The message definition statement specifies the message text that is to be displayed and the name used in the IDENT field of the message. Additionally, you can use the message definition statement to specify the number of FAO arguments to be included in the message text. Any number of message definitions can follow a .SEVERITY directive (or a .FACILITY directive if no .SEVERITY directive is included).

You can place qualifiers in any order before or after the message text.

You can use the severity level qualifiers either to override the severity level defined in a .SEVERITY directive or to replace .SEVERITY directives in your message source file. Only one message definition qualifier can be included per message definition.

Example

```
.TITLE          SAMPLE Error and Warning Messages
.IDENT          'VERSION 4.00'
.FACILITY       SAMPLE,1/PREFIX=ABC_ ❶
.SEVERITY      ERROR
UNRECOG        < Unrecognized keyword !AS>/FAO_COUNT=1 ❷
AMBIG          "Ambiguous keyword" ❸
.SEVERITY      WARNING
.BASE          10
SYNTAX         < Invalid syntax in keyword> ❹
.END
```

This message source file contains a .FACILITY directive ❶ and three message definitions ❷ ❸ ❹. The symbol names—UNRECOG, AMBIG, and SYNTAX—specified in the message definitions are combined with a prefix, ABC_ (defined

MESSAGE Commands

Message Definition

in the .FACILITY directive), to form the message symbols ABC_UNRECOG, ABC_ambiguous, and ABC_SYNTAX.

The message text of the UNRECOG ❷ and SYNTAX ❹ messages is delimited by angle brackets (<>); the message text of the AMBIG message ❸ is delimited by quotation marks ("").

In addition, the first message definition statement in this example includes the FAO directive !AS (which inserts an ASCII string at the end of the message text) and the corresponding qualifier /FAO_COUNT.

Page Directive

Forces page breaks in the output listing.

Format

.PAGE

Parameters

None.

Qualifiers

None.

Description

The .PAGE directive lets you specify page breaks in the output listing. You can specify only one page break per any one .PAGE directive; however, you can use the .PAGE directive as often as you like.

Example

```
.TITLE          SAMPLE Error and Warning Messages
.IDENT          'VERSION 4.00'
.FACILITY       SAMPLE,1/PREFIX=ABC_
.SEVERITY       ERROR

UNRECOG        < Unrecognized keyword !AS>/FAO_COUNT=1
AMBIG          < Ambiguous keyword>
.PAGE ❶

.SEVERITY       WARNING
.BASE          10
SYNTAX         < Invalid syntax in keyword>

.END
```

❶ This .PAGE directive forces a page break in the output listing after the AMBIG message definition.

MESSAGE Commands

Severity Directive

Severity Directive

Specifies the severity level to be associated with the messages that follow the .SEVERITY directive.

Format

```
.SEVERITY level
```

Parameter

level

Specifies the level of the condition that caused the message. The severity level codes are as follows:

| | |
|---------------|----------------------------------|
| SUCCESS | Produces an S code in a message. |
| INFORMATIONAL | Produces an I code in a message. |
| WARNING | Produces a W code in a message. |
| ERROR | Produces an E code in a message. |
| SEVERE | Produces an F code in a message. |
| FATAL | Produces an F code in a message. |

The SEVERE parameter is equivalent to the FATAL parameter; they can be used interchangeably.

Qualifiers

None.

Description

Following the .FACILITY directive, the message source file generally contains a .SEVERITY directive. If you do not specify the severity on each message definition with one of the message definition severity qualifiers, you must include a .SEVERITY directive. If you attempt to define a message without specifying a severity level, an error results.

A new .FACILITY directive cancels the previous severity level in effect.

Example

```
.TITLE          SAMPLE Error and Warning Messages
.IDENT          'VERSION 4.00'
.FACILITY       SAMPLE,1/PREFIX=ABC_
.SEVERITY       ERROR           ❶
UNRECOG        < Unrecognized keyword !AS>/FAO_COUNT=1
AMBIG          < Ambiguous keyword>
.SEVERITY       WARNING        ❷
.BASE          10
SYNTAX         < Invalid syntax in keyword>
.END
```

❶ ❷ The two .SEVERITY directives included in this message source file define the severity levels for three messages. The first two messages have a severity level of E; the third message has a severity level of W.

Title Directive

Specifies the module name and title text that is to appear at the top of each page of the output listing file.

Format

```
.TITLE  modname [listing-title]
```

Parameters

modname

Specifies a character string of up to 31 characters that is to appear in the object module as the module name.

listing-title

Defines the text to be used as the title of the listing. The title begins with the first nonblank character after the module name and continues through the next 28 characters. An exclamation point (!) within these 28 characters is treated as part of the title and not as a comment delimiter. The listing title has a maximum length of 28 characters and cannot be continued onto another line.

Qualifiers

None.

Example

```
.TITLE          SAMPLE ❶ Error and Warning Messages ❷
.IDENT          'VERSION 4.00'
.FACILITY       SAMPLE,1/PREFIX=ABC_
.SEVERITY       ERROR

UNRECOG        < Unrecognized keyword !AS>/FAO_COUNT=1
AMBIG          < Ambiguous keyword>

.SEVERITY       WARNING
.BASE          10
SYNTAX         < Invalid syntax in keyword>

.END
```

❶ The module name of the object module produced by this file is SAMPLE.

❷ The title of the output listing is defined as “Error and Warning Messages.”

MESSAGE Examples

The following examples demonstrate the use of message files and pointer files.

Creating an Executable Image Containing Message Data

The following example illustrates the steps involved in incorporating a message file within an executable image.

The message source file, TESTMSG.MSG, created with a text editor, contains the following lines:

```
.FACILITY      TEST,1 /PREFIX=MSG_  
.SEVERITY     ERROR  
SYNTAX        < Syntax error in string '!AS'>/FAO_COUNT=1  
ERRORS        < Errors encountered during processing>  
.END
```

You compile the message source file by entering the following command:

```
$ MESSAGE TESTMSG
```

You compile the FORTRAN source file by entering the following command:

```
$ FORTRAN TEST
```

You link the message object module TESTMSG.OBJ to the FORTRAN object module TEST.OBJ by entering the following command:

```
$ LINK/NOTRACE TEST+TESTMSG
```

You execute the image by entering the following command:

```
$ RUN TEST
```

If an error occurs when you execute the program, the system displays the following messages:

```
%TEST-E-SYNTAX, Syntax error in string ABC  
%TEST-E-ERRORS, Errors encountered during processing
```

Creating an Executable Image Containing a Pointer

The following example demonstrates how to create an executable image that contains a pointer to a nonexecutable message file.

You compile the message source COBOLMSG by entering the following command:

```
$ MESSAGE/NOSYMBOLS COBOLMSG
```

You link the object module COBOLMSG.OBJ to create the nonexecutable message file by entering the following command:

```
$ LINK/SHAREABLE=SYS$MESSAGE:COBOLMF COBOLMSG.OBJ
```

You create the pointer object module MESPNTNTR.OBJ, which contains a pointer to the nonexecutable message file COBOLMF.EXE, by entering the following command:

```
$ MESSAGE/FILE_NAME=COBOLMF /OBJECT=MESPNTNTR COBOLMSG
```

You link the pointer object module MESPNTNTR.OBJ to the COBOL program object module COBOLCODE.OBJ by entering the following command:

```
$ LINK COBOLCODE,MESPNTNTR
```

MESSAGE Examples

You execute the program by entering the following command:

```
$ RUN COBOLCODE
```

The system then displays the messages defined in COBOLMSG.

B

.BASE directive, MSG-20
Base message number directive
 See .BASE directive
Binary operators, MSG-9
Built-in value types, CDU-8, CDU-25

C

CDU
 See Command Definition Utility
Character case, LIB-5
Character strings
 See Strings
Clauses, CDU-20
CLI (command language interpreter), CDU-3
CLI routines, CDU-3, CDU-18
 CLI\$DCL_PARSE, CDU-49
 CLI\$DISPATCH, CDU-49
 CLI\$GET_VALUE, CDU-48, CDU-49
 CLI\$PRESENT, CDU-48, CDU-49
 sample programs, CDU-48
Command definition files, CDU-6
 changing syntax, CDU-7 to CDU-8
 creating, CDU-6 to CDU-16
 defining verbs, CDU-10
 for sample program, CDU-48, CDU-49
 processing, CDU-16 to CDU-18
 statements in, CDU-20 to CDU-38
 TYPE clause
 defining value types, CDU-8
 VALUE clause
 for defining parameters, qualifiers,
 keywords, CDU-8
Command Definition Language statements,
 CDU-7
Command Definition Utility (CDU), CDU-3
 See also SET COMMAND command
 changing syntax, CDU-7
 defining values, CDU-8
 defining verbs, CDU-10
 examples, CDU-48 to CDU-51
 exiting, CDU-19
 invoking, CDU-19

Command language interpreter
 See CLI
Command processing
 See DCL
Command strings, CDU-3 to CDU-4
Command tables, CDU-4
 adding commands to, CDU-16, CDU-45
 creating, CDU-17
 creating object modules for, CDU-6
 deleting commands from, CDU-17, CDU-41
 input files, CDU-46
 listing files, CDU-42
 object modules, CDU-17, CDU-43
 output files, CDU-44
Comment lines
 in help files, LIB-8

D

Data files
 reducing and expanding, LIB-12
/DATA qualifier
 using to save disk space, LIB-12
DCL (DIGITAL Command Language)
 CLI routines, CDU-18
 command processing, CDU-3 to CDU-4
DEFINE SYNTAX statement, CDU-21
 changing syntax, CDU-7
 DISALLOW clause, CDU-23
 examples, CDU-8, CDU-28
 format, CDU-7, CDU-23
 IMAGE clause, CDU-24
 PARAMETER clauses, CDU-22, CDU-24 to
 CDU-25
 QUALIFIER clauses, CDU-25 to CDU-27
 ROUTINE clauses, CDU-27
 SYNTAX keywords, CDU-29
 table of syntax changes, CDU-21 to CDU-23
DEFINE TYPE statement, CDU-9, CDU-29
 acceptable keyword clauses, CDU-29
 acceptable type clauses, CDU-29
 DEFAULT clauses, CDU-29
 defining qualifier keywords, CDU-31
 examples, CDU-9
 format, CDU-9, CDU-29
 keywords referenced by VALUE, CDU-29
 LABEL clauses, CDU-29

DEFINE TYPE statement (cont'd)
NEGATABLE clauses, CDU-29
SYNTAX clauses, CDU-29
VALUE clauses, CDU-29 to CDU-30
with DEFINE VERB statement, CDU-9
with VALUE clause, CDU-9
DEFINE VERB statement, CDU-32
DISALLOW clauses, CDU-10, CDU-32
 definition paths, CDU-13 to CDU-14
 keyword paths, CDU-12 to CDU-13
 operators for, CDU-14 to CDU-15
examples, CDU-9, CDU-10, CDU-36
format, CDU-10, CDU-32
IMAGE clauses, CDU-32
PARAMETER clauses, CDU-33 to CDU-34
QUALIFIER clauses, CDU-34 to CDU-36
ROUTINE clauses, CDU-36
SYNONYM clauses, CDU-36
with DEFAULT clause, CDU-31
with DEFINE SYNTAX statement, CDU-8
Definition paths
 for DISALLOW clause, CDU-13 to CDU-14
Definition statements, MSG-4
DIGITAL Command Language
 See DCL
Directives
 for MESSAGE, MSG-4
Disk space
 saving, LIB-12

E

ELF sharable image, LIB-5
.END directive, MSG-21
End message directive
 See .END directive
Executable and Linking Format (ELF), LIB-3
Expressions
 in message source files, MSG-9

F

Facility directive
 See .FACILITY directive
.FACILITY directive, MSG-22 to MSG-23
 /PREFIX qualifier, MSG-22
 /SHARED qualifier, MSG-22
 /SYSTEM qualifier, MSG-22
Facility name
 in .FACILITY directive, MSG-22
Facility number
 in .FACILITY directive, MSG-22
Facility object modules, MSG-6
FAO argument, MSG-3, MSG-26, MSG-27
Files
 inserting, LIB-31

File types
 default for command definition files, CDU-6
 default for libraries, LIB-13
 changing, LIB-13
 default for object libraries, LIB-3

G

Global symbols
 See Message symbols
GSTs (global symbol tables), LIB-4

H

Help files
 comment lines in, LIB-8
 creating, LIB-6, LIB-7
 formatting, LIB-7
 qualifier lines in, LIB-8
 restrictions in, LIB-7
Help libraries, LIB-3, LIB-6
 character case in, LIB-5
 index keywords in, LIB-6
 key names in, LIB-6, LIB-7
HELP LIBRARY command
 display, LIB-10
Help modules
 naming, LIB-6
Help text
 example of, LIB-9
 retrieving, LIB-10

I

.IDENT directive, MSG-24
Identification directive
 See .IDENT directive
IDENT statements, CDU-15, CDU-37
Index keywords
 in help libraries, LIB-6
Input files
 default file types, LIB-14
Input file specifications, LIB-13
Inserting files/modules, LIB-31
 See also LIBRARY command, /REPLACE
 qualifier

K

Key lines
 formatting, LIB-7
Key names
 character restrictions in, LIB-7
 in help libraries, LIB-6, LIB-7, LIB-11
Key numbers, LIB-7
 See also Modules

Keys, LIB-5, LIB-6, LIB-7

See also Library keys

Keyword paths

for DISALLOW clause, CDU-12 to CDU-13

Keywords, CDU-3, LIB-6

See also DEFINE TYPE statement

defining, CDU-9 to CDU-10, CDU-31

L

LBR routines, LIB-12

LIBRARIAN

See Librarian utility

Librarian utility (LIBRARIAN)

See also LIBRARY command

command qualifiers, LIB-15

compressing macro libraries, LIB-45

creating new libraries, LIB-20

cross-reference listings, LIB-23

deleting modules from libraries, LIB-25

directing output, LIB-14

history record headers, LIB-30

library list, LIB-32

specifying files, LIB-40

exiting, LIB-14

extracting files, LIB-26

global symbols, LIB-28, LIB-36, LIB-41,

LIB-48

help files, LIB-6, LIB-7

help libraries, LIB-6, LIB-7

HELP LIBRARY command display, LIB-10

help text example, LIB-9

inserting modules, LIB-31, LIB-35

invoking, LIB-14

key lines in help files, LIB-7

LIBRARY command format, LIB-13

library file specifications, LIB-13

linking modules, LIB-42

macro libraries, LIB-34

object module libraries, LIB-38

recovering storage space, LIB-18

restrictions, LIB-14

retrieving help text, LIB-10

selecting entries after date/time, LIB-44

sharing image libraries, LIB-43

specifying date/time, LIB-17

specifying input files, LIB-13, LIB-14

specifying library files, LIB-13

text libraries, LIB-46

using to save disk space, LIB-12

Libraries

character case in, LIB-20

macro, LIB-34

object module, LIB-3, LIB-38

reformatting, LIB-18, LIB-24

sizes of, LIB-18, LIB-20, LIB-31

structure of, LIB-4

Libraries (cont'd)

text, LIB-46

types of, LIB-3

LIBRARY command, LIB-13

See also Librarian utility

/ALPHA qualifier, LIB-16

/BEFORE qualifier, LIB-17

/COMPRESS qualifier, LIB-18 to LIB-19

using with /OUTPUT, LIB-40

/CREATE qualifier, LIB-13, LIB-20 to LIB-22

/CROSS_REFERENCE qualifier, LIB-23

using with /ONLY, LIB-39

using with /OUTPUT, LIB-40

/DATA qualifier, LIB-24

See also LIBRARY command, /COMPRESS

qualifier

using with /OUTPUT, LIB-40

/DELETE qualifier, LIB-25

/EXTRACT qualifier, LIB-13, LIB-26

using with /OUTPUT, LIB-40

/FULL qualifier, LIB-27

using with /HISTORY, LIB-30

/GLOBALS qualifier, LIB-28

/HELP qualifier, LIB-29

/HISTORY qualifier, LIB-30

/INSERT qualifier, LIB-13, LIB-31

maximum record size, LIB-31

/LIST qualifier, LIB-32

using with /BEFORE, LIB-17

using with /FULL, LIB-27

using with /HISTORY, LIB-30

using with /NAMES, LIB-36

using with /ONLY, LIB-39

using with /SINCE, LIB-44

/LOG qualifier, LIB-33

See also LIBRARY command, /DELETE

qualifier

See also LIBRARY command, /REPLACE

qualifier

/MACRO qualifier, LIB-34

/MODULE qualifier, LIB-35

using with /INSERT, LIB-35

/NAMES qualifier, LIB-36 to LIB-37

/OBJECT qualifier, LIB-38

/ONLY qualifier, LIB-39

/OUTPUT qualifier, LIB-40

using with /COMPRESS, LIB-18

using with /CROSS_REFERENCE, LIB-23

using with /EXTRACT, LIB-26

/REMOVE qualifier, LIB-41

/REPLACE qualifier, LIB-13, LIB-41

/SELECTIVE_SEARCH qualifier, LIB-42

/SHARE qualifier, LIB-43

/SINCE qualifier, LIB-44

/SQUEEZE qualifier, LIB-45

/TEXT qualifier, LIB-46

/VAX qualifier, LIB-47

LIBRARY command (cont'd)
 /WIDTH qualifier, LIB-48
Library file specifications, LIB-13
 default file types, LIB-13
Library keys, LIB-5
Linker, LIB-3, LIB-4, LIB-5
Listing directives, MSG-29, MSG-31
Literal directive
 See .LITERAL directive
.LITERAL directive, MSG-25

M

Macro libraries, LIB-3, LIB-34
 character case in, LIB-5
Match operations, LIB-5
MESSAGE
 See Message utility
Message code, MSG-4
MESSAGE command, MSG-10
 See also Message utility
 /ALPHA qualifier, MSG-12
 examples, MSG-32
 /FILE_NAME qualifier, MSG-13
 /LIST qualifier, MSG-14
 /OBJECT qualifier, MSG-15
 /SYMBOLS qualifier, MSG-16
 /TEXT qualifier, MSG-17
 using, MSG-5
 /VAX qualifier, MSG-18
Message definitions
 /ERROR qualifier, MSG-27
 /FAO_COUNT qualifier, MSG-26
 /FATAL qualifier, MSG-27
 /IDENTIFICATION qualifier, MSG-26
 /INFORMATIONAL qualifier, MSG-27
 in message source files, MSG-26
 qualifiers, MSG-26
 /SEVERE qualifier, MSG-27
 statements, MSG-4
 /SUCCESS qualifier, MSG-26
 /USER_VALUE qualifier, MSG-26
 /WARNING qualifier, MSG-27
Message directive commands, MSG-19
Message files
 See also Message source files and Message
 object modules
 listing, MSG-14
 nonexecutable, MSG-6
 creating, MSG-6
 specifying, MSG-13
Message libraries, MSG-6
Message object modules
 creating, MSG-5, MSG-15, MSG-24, MSG-31
 file specifications, MSG-15
 formatting, MSG-31
 global symbols, MSG-16

Message object modules (cont'd)
 linking, MSG-6
 pointers, MSG-6, MSG-13
 text, MSG-17
Message pointers
 creating, MSG-7
 example, MSG-32
 using, MSG-6, MSG-7
Messages
 constructing, MSG-4
 example, MSG-3
 format, MSG-3
Message source files, MSG-4
 coding, MSG-19
 comments in, MSG-8
 compiling, MSG-5
 elements of, MSG-4
 expressions in, MSG-9
 format, MSG-5, MSG-21, MSG-29
 programming example, MSG-5
 sample, MSG-22
 symbols in, MSG-9, MSG-25, MSG-26
Message source file statements, MSG-8, MSG-19
 .BASE directive, MSG-20
 .END directive, MSG-21
 .FACILITY directive, MSG-22
 format, MSG-5
 .IDENT directive, MSG-24
 listing directives, MSG-29, MSG-31
 .LITERAL directive, MSG-25
 message definitions, MSG-26
 .PAGE directive, MSG-29
 .SEVERITY directive, MSG-30
 .TITLE directive, MSG-9, MSG-31
Message symbols, MSG-4, MSG-8, MSG-26
Message utility (MESSAGE)
 See also MESSAGE command
 command qualifiers, MSG-11
 controlling output, MSG-11
 examples, MSG-32
 exiting, MSG-10
 invoking, MSG-10
Module headers, LIB-4
Module name tables (MNT), LIB-4
Modules
 creating, LIB-6
 formatting, LIB-7
 key numbers in, LIB-7
 terminating, LIB-7
MODULE statements, CDU-15, CDU-38

N

Naming help modules, LIB-6

O

- Object libraries, LIB-3, LIB-38
 - character case in, LIB-5
- Object modules
 - See also Message object modules
 - creating, CDU-49
 - for command tables, CDU-6, CDU-17, CDU-43
 - statements for, CDU-15
- Operators
 - for DISALLOW clause, CDU-14 to CDU-15
- Output
 - directing, LIB-14, LIB-18, LIB-40

P

- Page directive
 - See .PAGE directive
- .PAGE directive, MSG-29
- Parameters
 - defining, CDU-24, CDU-33
- Pointers
 - See Message pointers
- Process command tables
 - adding commands to, CDU-48
 - deleting commands from, CDU-41
- Processes
 - adding commands to, CDU-5
 - command tables, CDU-4
- Programs
 - creating, MSG-6
 - example, MSG-5
 - executing, MSG-6
- \$PUTMSG routine, MSG-4

Q

- Qualifier lines
 - help files, LIB-8
- Qualifiers
 - for CDU, CDU-39
 - defining, CDU-25, CDU-34
 - for LIBRARY command, LIB-15
 - for MESSAGE, MSG-11

R

- Radix operators, MSG-9
- Routines
 - LBR, LIB-12

S

- SET COMMAND command, CDU-19
 - /ALPHA qualifier, CDU-40
 - delete mode, CDU-17
 - /DELETE qualifier, CDU-41
 - input for, CDU-46
 - /LISTING qualifier, CDU-42
 - object mode, CDU-17
 - /OBJECT qualifier, CDU-43
 - /OUTPUT qualifier, CDU-44
 - processing modes, CDU-16
 - qualifiers for, CDU-39
 - replace mode, CDU-16
 - /REPLACE qualifier, CDU-45
 - /TABLE qualifier, CDU-46
 - /VAX qualifier, CDU-47
- SET MESSAGE command
 - using, MSG-8
- Severity directive
 - See .SEVERITY directive
- .SEVERITY directive, MSG-30
- Severity levels, MSG-3
- Shareable image, LIB-5
- Shareable image library, LIB-4
- Shareable images, LIB-43
- Source files
 - See Message source files
- Source file statements
 - See Message source file statements
- Special characters, LIB-7
- Statements
 - in command definition files, CDU-20
 - message definition, MSG-4
- Strings, CDU-6
- Subkeys, LIB-7, LIB-8
- Symbols, CDU-6
 - in message source files, MSG-9
- Syntax
 - See DEFINE SYNTAX statement
- Syntax-name verb clauses, CDU-7
- System command tables, CDU-4, CDU-5
- System help library, LIB-10

T

- Tables
 - See Command tables
- Text libraries, LIB-3, LIB-46
 - character case in, LIB-5
- Title directive
 - See .TITLE directive
- .TITLE directive, MSG-31
 - in message source files, MSG-9

Types

See Built-in value types

V

Values

See also Built-in value types
defining, CDU-8 to CDU-10

Verbs

See also DEFINE VERB statement
defining, CDU-10

W

Wildcard characters, LIB-7